

R1 Kiddy Series

(NAC4-8K-DS)

NAC4K-DS/NAC5K-DS/NAC6K-DS

NAC7K-DS/NAC8K-DS



Contents

1. Introduction	3
1.1. Introduction	3
1.2. Applied Designations	3
1.3. Important Safety Information	4
1.4. System Sizing	4
2. Technical Description of Inverters	6
2.1. Mechanical design.....	6
2.2. Electrical system design	7
2.3. Technical data.....	7
3. Installation and startup.....	10
3.1. Package information.....	10
3.2. Installation environment.....	10
3.3. Installation Position.....	11
3.4. Mounting Procedure.....	12
3.5. Electrical connection.....	13
3.5.1. Connection to the grid (AC output).....	13
3.5.2. Connection to PV string (DC input).....	14
3.5.3. RS485 Communication.....	15
3.6. Starting the Inverter.....	16
4. User Interface	17
4.1. Led and Key.....	17
4.2. LCD Display.....	17
4.3. Factory setting	19
4.4. Setting language.....	19
4.5. Setting modulebus address	19
5. Warranty.....	20
5.1. Warranty Claim Procedure	20
5.2. Service after Warranty Expiration	20
6. Contact Information.....	21
Appendix A: FAQ (Frequently asked questions)	22

Copyright Declaration

The copyright of this manual belongs to Renacpower Technolog Co., Ltd. Any corporation or individual should not plagiarize, partially copy or fully copy it (including software, etc.), and no reproduction or distribution of it in any form or by any means. All rights reserved. Renacpower reserves the right of final interpretation. This manual is subject to change according to user's or customer's feedback. Please check latest version at: <http://www.renacpower.com>.

1. Introduction

1.1. Introduction









This manual describes solar inverters :
NAC4K-DS/NAC5K-DS/NAC6K-DS/NAC7K-DS/NAC8K-DS.

These inverters are transformerless based inverter.

Please read the safety instructions in this manual first. Throughout the manual it is assumed that the reader is familiar with AC and DC installations and knows the rules and regulations for electrical equipment and for connecting it to the utility AC grid. It is especially important to be familiar with the general safety rules for working with electrical equipment.

1.2. Applied Designations

Throughout the manual important information is shown at different levels depending on the character of the information, as shown here:

	Safety information important for human safety. Violation of warnings may result in injury to persons or death.
	Danger of high voltage and electric shock!
	Signals danger due to electrical shock and indicates the time (5 minutes) to allow after the inverter has been turned off and disconnected to ensure safety in any installation operation.
	Danger of hot surface!
	Product should not be disposed as normal household waste.
	CE Mark
	ROHS Mark
	Information important for the protection of property. Violation of this type of information may cause damage and loss of property.
	Useful additional information or "Tips and Tricks" on specific subjects.

1.3. Important Safety Information

Read this before installing, operating or maintaining the inverter.



Before installation:

Check for damage to inverter and packaging. If you are in doubt, please contact your supplier before installing the inverter. Check the voltages of the solar modules and make sure they are within the limits of the inverter specifications before connecting them to the inverter.

Installation:

Only trained and authorized personnel familiar with local electrical codes may install the inverter. For optimum safety, please follow the steps described in this manual. Keep in mind that the inverter has two voltage carrying sides, the PV input and the AC grid.

Disconnecting the inverter:

Always disconnect the AC line first! Afterwards disconnect the PV lines. Note that the inverter can still be charged with very high voltages at hazardous levels even when it is disconnected from grid and solar modules. Wait at least 5 min. before proceeding, after having disconnected from grid and PV panels.

operating the inverter:

Before connecting the AC grid to the inverter, make sure that the installation cover is mounted again. The inverter must not be open during operation.

Maintenance and modification:

Only authorized personnel are allowed to repair or modify the inverter. To ensure optimum safety for user and environment, only the original spare parts available from your supplier should be used.

Functional safety parameters:

Unauthorized changes of functional safety parameters may cause injury or accidents to people or inverter. Additionally it will lead to the cancelling of all inverter operating approval certificates.

1.4. System Sizing



When dimensioning a photovoltaic system, it must be ensured that the open circuit voltage of the PV string never exceeds the maximum permissible input voltage of 600V DC. The PV string open circuit voltage during parallel string operation is 550V. Higher voltages may result in permanent damage to the inverter.

The selection of PV string output should be based on the optimum utilization of the invested capital compared to the expected annual energy yield from the system. This optimization depends on local weather conditions and should be considered in each individual case.

The inverter incorporates an input power limiting device, which automatically keeps the power at levels that are safe for the inverter. The limitation depends mainly on internal and ambient temperatures. The limitation is calculated continuously and always allows the maximum possible amount of energy to be produced.

Please use the tool supplied by Renacpower when dimensioning a photovoltaic system.

2. Technical Description of Inverters

2.1. Mechanical design

Figure 2-1 shows the outline dimensions of NAC4K-DS/NAC5K-DS/NAC6K-DS/NAC7K-DS/NAC8K-DS:

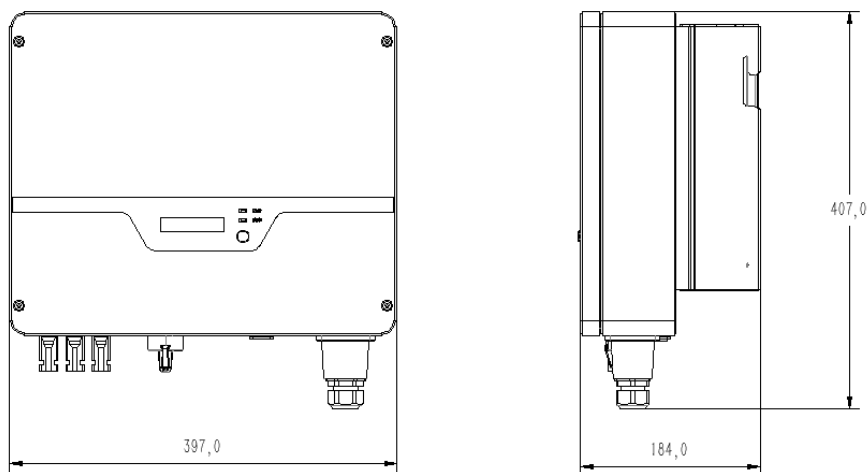

Figure 2-1 Outline dimensions

Figure 2-2 shows the electrical terminals of NAC4K-DS/NAC5K-DS/NAC6K-DS/NAC7K-DS/NAC8K-DS:

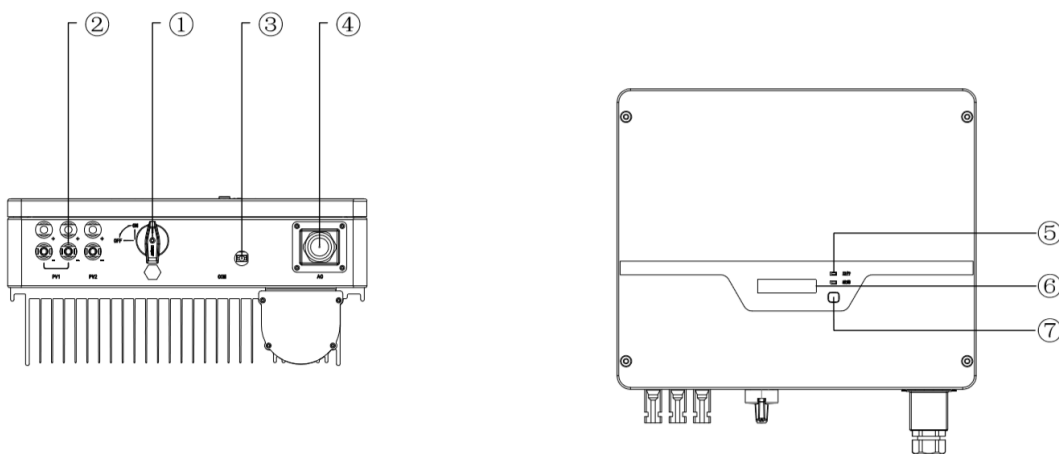

Figure 2-2 Electrical Terminals

1	DC Switch	2	DC (PV terminal)
3	Communication port	4	AC terminal
5	LED (running)	6	LED (fault)
7	KEY		



For safety reasons, the use of a DC switch is recommended. Between the PV modules and the power modules may be mandatory in some countries.

2.2. Electrical system design

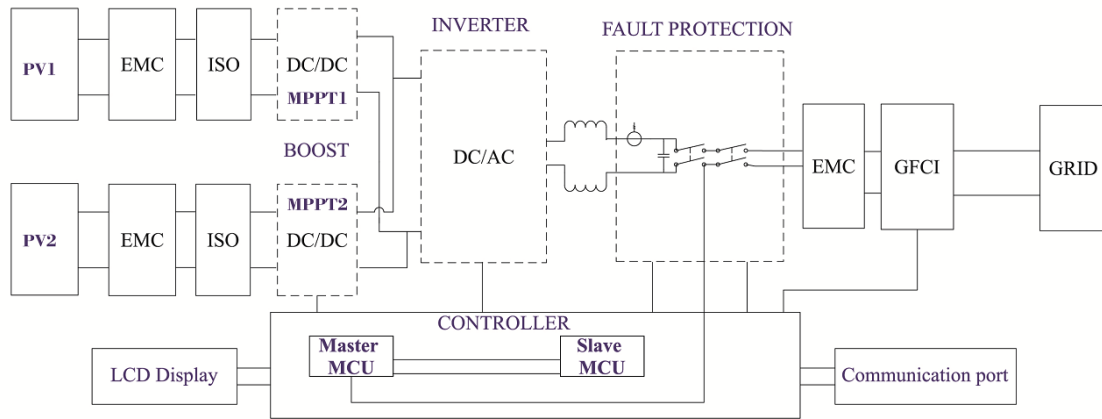

Figure 2-3 wiring diagram of the inverter system

Please refer to chapter 3 for the detail connecting and install methods.

2.3. Technical data

Model	NAC4K-DS	NAC5K-DS	NAC6K-DS	NAC7K-DS	NAC8K-DS
INPUT					
MAX. INPUT POWER	4700W	5800 W	7000 W	8100 W	8600 W
MAX. PV VOLTAGE	600 Vdc	600 Vdc	600 Vdc	600 Vdc	600 Vdc
MPPT VOLTAGE RANGE	100 ~550 Vdc	100 ~ 550 Vdc	100 ~ 550 Vdc	100 ~550 Vdc	100 ~550 Vdc
START VOLTAGE	80 Vdc	80 Vdc	80 Vdc	80 Vdc	80 Vdc
MPPT NUMBER	2	2	2	2	2
MAX. INPUT CURRENT	10Adc	10Adc+10dc	10Adc+10dc	18Adc+10dc	18Adc+10dc
Isc	13A	13Adc+13Adc	13Adc+13Adc	13Adc+13Adc	24Adc+13Adc
Max inverter backfeed current to the array	0A	0A	0A	0A	0A
PV TERMINAL NUMBER	1+1	1+1	1+1	2+1	2+1
DC SWITCH	Y	Y	Y	Y	Y
Over Voltage Category	II				
OUTPUT					
RATED AC POWER	4000 VA	5000 VA	6000 VA	7000 VA	8000 VA

MAX. AC POWER	4400 VA	5500 VA	6600 VA	7700 VA	8000 VA
RATED AC VOLTAGE	230Vac; L+N+PE				
AC VOLTAGE RANGE	160~290 Vac				
AC FREQUENCY RANGE	50Hz/60Hz ±5Hz				
POWER FATOR	-0.8~0.8 controllable				
Over Voltage Category	III				
RATED AC CURRENT	17.4Aac	21.8Aac	26.1Aac	30.5Aac	34.8Aac
MAX. AC CURRETN	19.2Aac	24Aac	28.7Aac	33.5Aac	34.8Aac
Max output overcurrent protection	30A	36A	42A	48A	54A
Max output fault current	37A	54A	54A	67A	67A
THDi	< 3%	< 3%	< 3%	< 3%	< 3%
SYSTEM					
MAX. EFFICIENCY	97.8%	97.8%	97.8%	98.1%	98.1%
EU. EFFICIENCY	97.2%	97.2%	97.2%	97.5%	97.5%
MPPT EFFICIECNY	99.9%	99.9%	99.9%	99.9%	99.9%
NIGHT CONSUMPITON	<1W				
TOPOLOGY	Transformerless				
HEAT DISSIPATION	Natural convection				
PROTECT					
INSULATION DETECTION	YES				
DC REVERSE PROTECTION	YES				
ANTI-ISLAND PROTECTINO	YES				
RESIDUAL CURRENT DETECTION	YES				
THERMAL PROTECTINO	YES				
GENERAL PARAMETERS					
DIMENSIONS	W×H×D=395×330×185(mm)				
WEIGHT	14kg	15kg	15kg	16kg	16kg
DISPLAY	2*16 dot LCD				
COMMUNICATION	RS485 (OPTIONAL) /WIFI (OPTIONAL) /GPRS (OPTIONAL)				
AMBIENT TEMPERATURE	-25 °C ~ +60 °C				

Environment category	Outdoor & Indoor
OPERATING ALTITUDE	< 2000m
PROTECTION DEGREE	IP65
NOISE EMISION	<30db @ 1 m
WARRANTY	Standard 5years
Certifications	IEC/EN62109-1/2 ,IEC/EN6000-6-1/2/3/4, NB/T32004-2013, VDE0126, VDE4105, AS/NES4777.2 ,IEC61727, IEC62116 ,NB/T32004-2013

3. Installation and startup



Warning!

Before installation and maintenance, AC and DC side doesn't carry electricity, but if DC side is just disconnected, capacitance still contains electricity, so please wait for at least 5 minutes to ensure the capacitors completely release the energy and inverter is not electrified.



Note!

Inverters must be installed by qualified person.

3.1. Package information

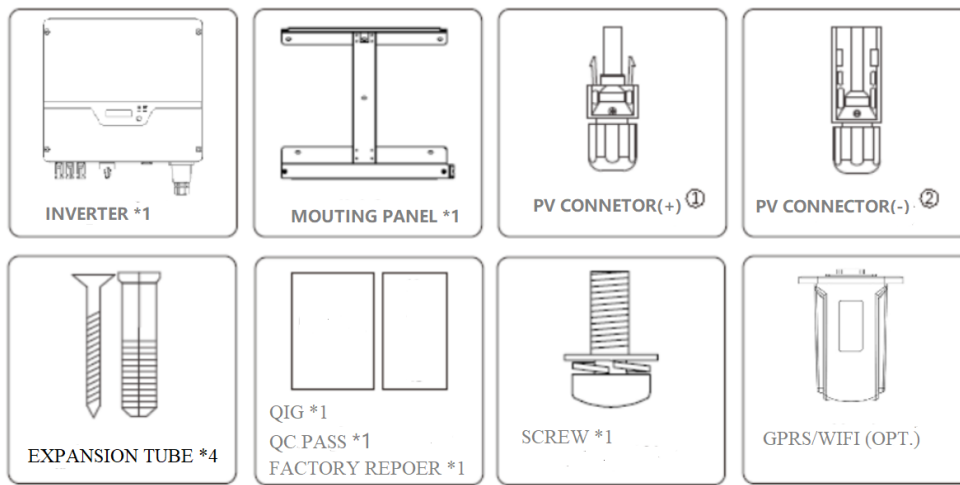

①There are 2 PV+ connectors for NAC4/5/6K-DS and 3 PV connectors for NAC7/8K-DS

②There are 2 PV- connectors for NAC4/5/6K-DS and 3 PV connectors for NAC7/8K-DS

Figure 3-1 package information

3.2. Installation environment

- In order to achieve optimal performance, the ambient temperature should be kept lower than 45 °C.
- For the convenience of checking the LCD display and possible maintenance activities, please install the inverter at eye level.
- Inverters should NOT be installed near inflammable or explosive items. Any strong electro-magnetic equipment should be kept away from installation site.
- Product label and warning symbol shall be clear to read after installation.
- Please do not install inverter under direct sunlight, rain and snow.

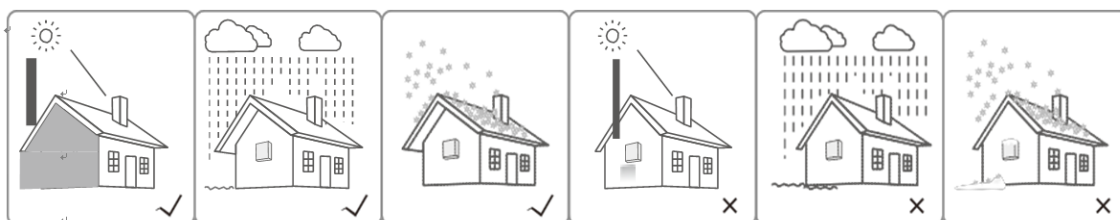

Figure 3-2 installation environment

3.3. Installation Position

!

- The installation method and mounting location must be suitable for the inverter's weight and dimensions.
- Mount on a solid surface.
- Select a well ventilated place sheltered from direct sun radiation.

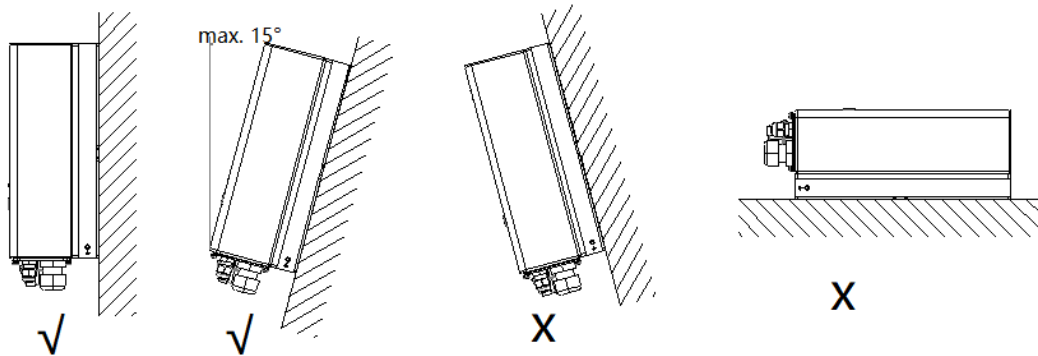

Figure 3-2 installation position

In consideration of heat dissipation and convenient dismantlement, the minimum clearances around the inverter should be no less than the following value

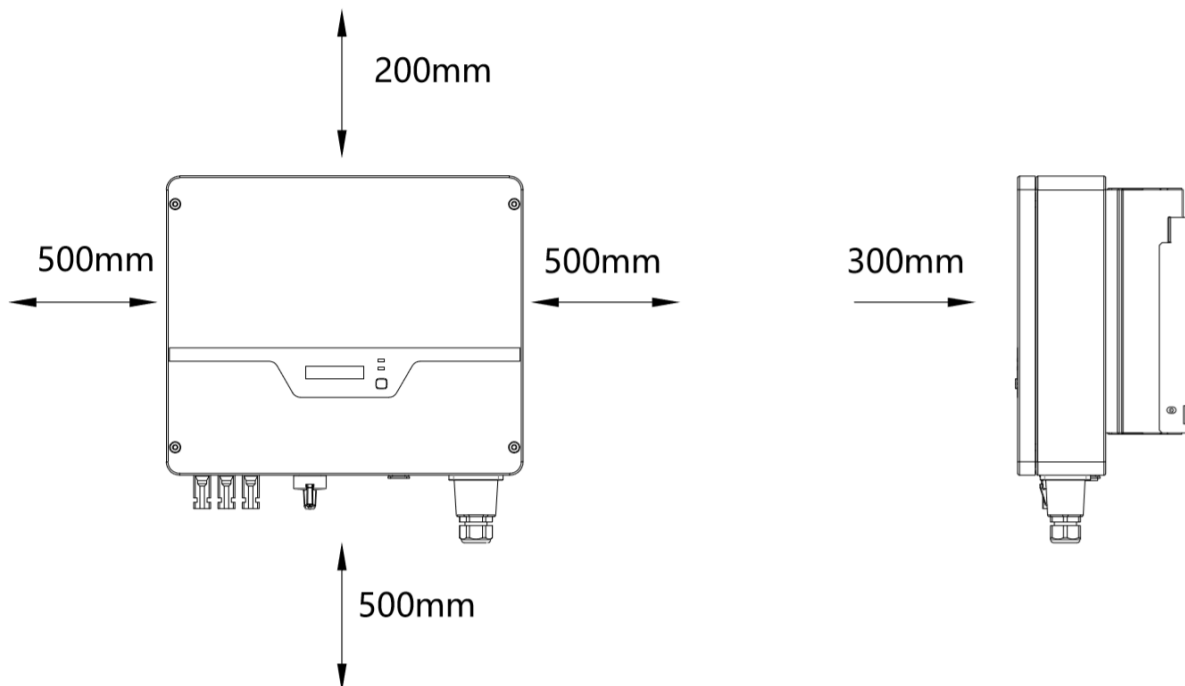

Figure 3-3 Distance required of Invertors

3.4. Mounting Procedure

Step1: Drill 4 Fix Ø8 holes in the wall according to the dimensions

Step2: Fix the wall mounting bracket on the wall with 4 expansion bolts in accessory bag

Step4: Place the inverter on the wall-mounted bracket and install the fix screw

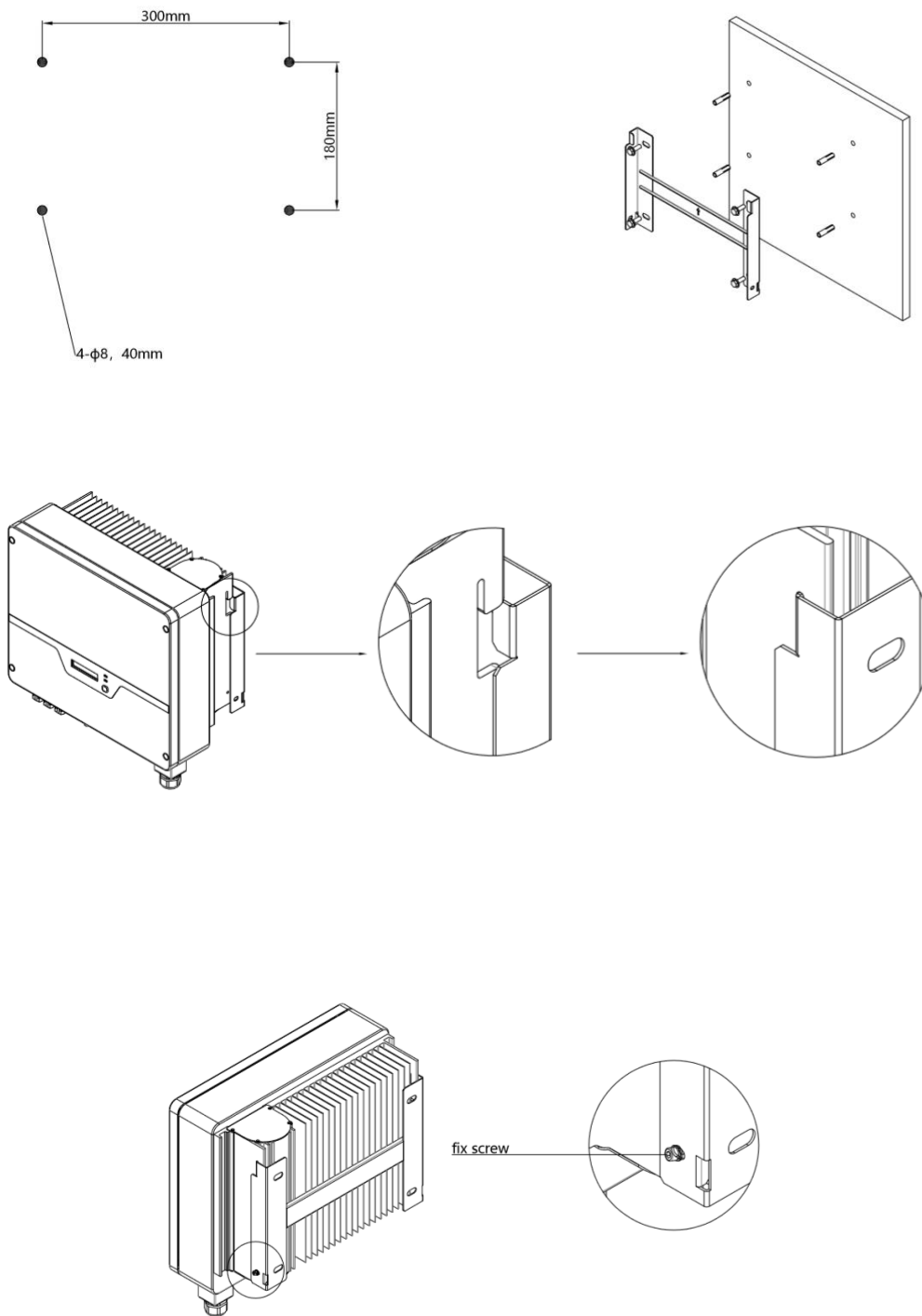

Figure 3-4 mounting the inverter

3.5. Electrical connection

3.5.1. Connection to the grid (AC output)



- (1) Add breaker or fuse to AC side, the specification should be more than 1.25 times of rated AC output current.
- (2) The PE line of inverter should be connected to the earth, make sure the impedance of neutral wire and earth wire less than 10 ohm.
- (3) Disconnect the breaker or fuse between the inverter and the utility.
- (4) The integrated leakage current detection device of the inverter can detect external leakage current in real time. When the detected leakage current exceeds the limit value, inverter will quickly disconnect with the grid. If the leakage current protection device is installed externally, the action current should be 300mA or higher.

Connect the inverter to the grid as follows:

- (1) Strip off N/L1/L2/L3 cables as figure 3-5:

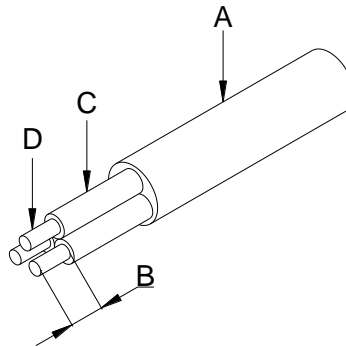

No.	Description	Remark
A	protective layer	diameter ranges : 9-16mm
B	length of stripped off	12mm
C	insulate layer	50mm
D	cross section of ac cables	6-10mm ²

Figure 3-5 Strip off PE/N/L cables

- (2) Insert AC cables through cable gland from outside, Pull the cables through and fix L/N/PE cables ends to the terminals according to markings



Fix (Torque: 2~2.5 N.m) the connector of AC cable to the corresponding terminals

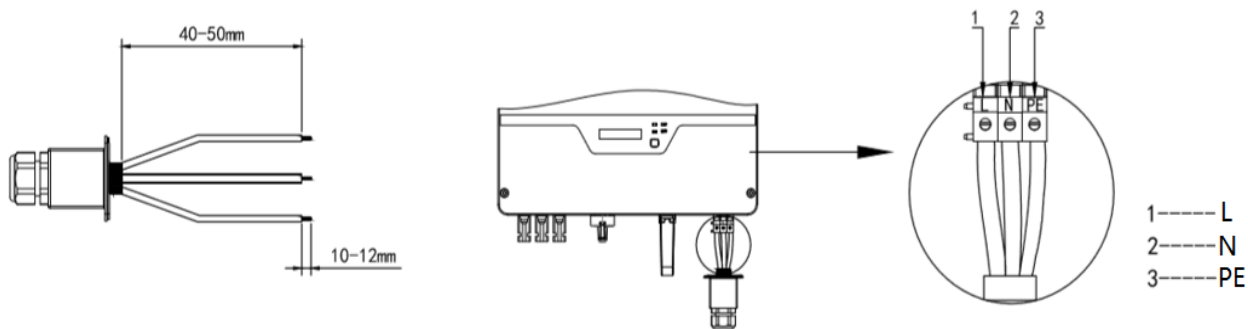



Figure 3-7 Connect the inverter to the grid

(4): Screw waterproof coupling and Screw cap nut tightly onto the cable.

3.5.2. Connection to PV string (DC input)



- (1) Before connecting PV string, make sure DC switch is turned off
- (2) Make sure PV string polarity confirms with DC connector, otherwise, it will cause damage to inverter
- (3) Make sure the maximum open circuit voltage (V_{oc}) of each PV string does not exceed the inverter input voltage V_{max} under any condition
- (4) Do not connect positive or negative pole of PV string to earth wire. Otherwise, it will cause damage to inverter

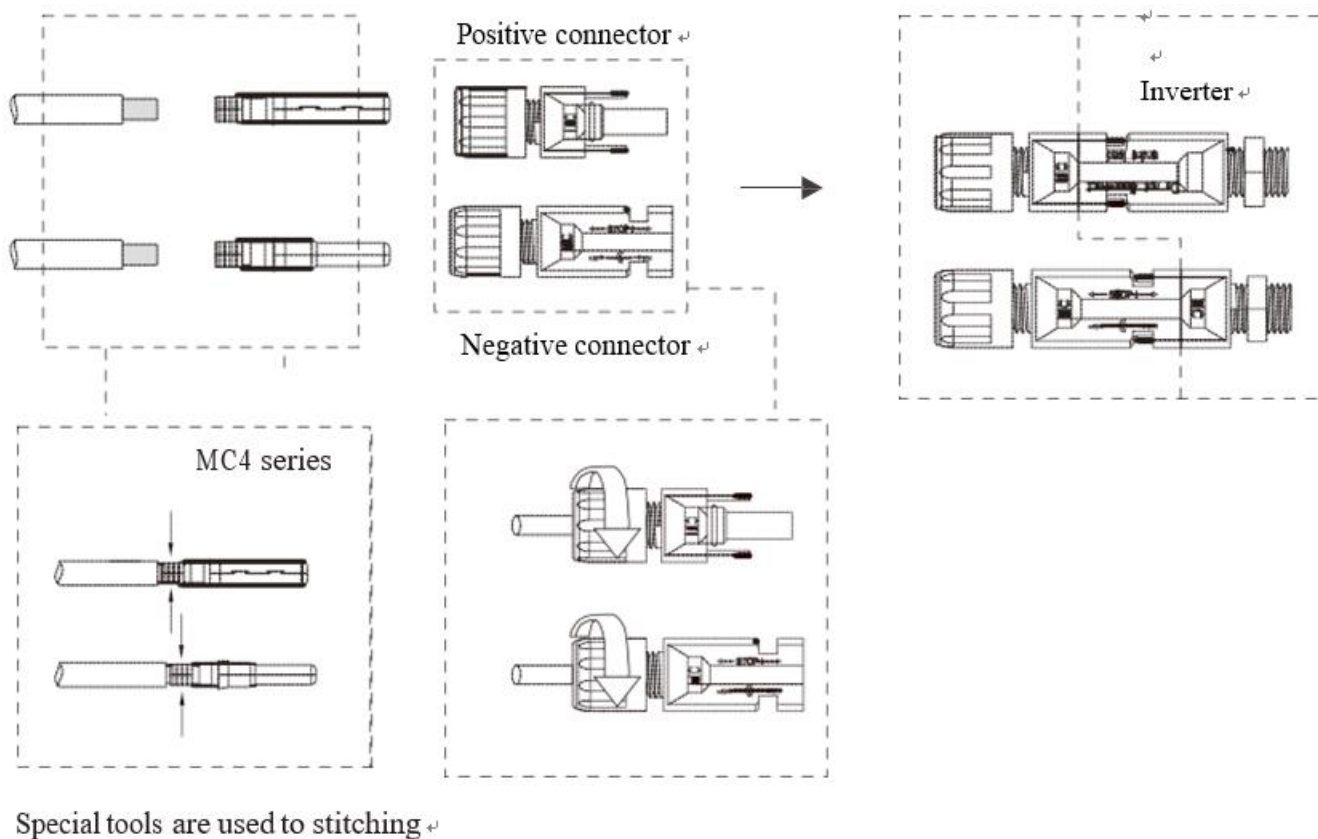

Figure 3-8 Connect the PV string

3.5.3. RS485 Communication



- Please make sure the RS485 connecting cables not exceed 1000m.
- Communication lines must be separated from other power lines to avoid communications interference.

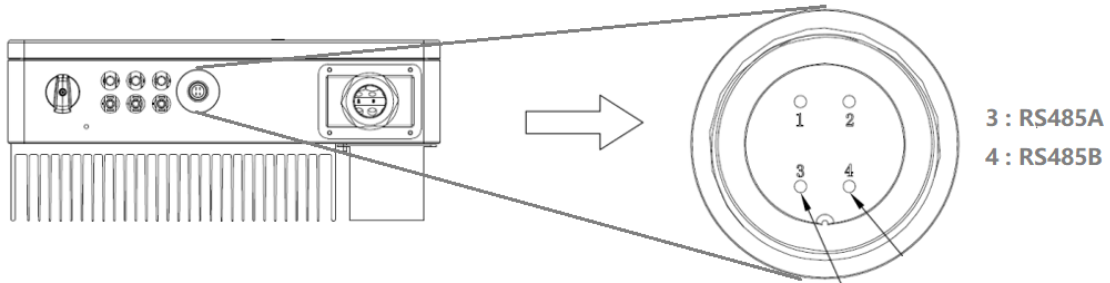

Figure 3-9 RS485 Port

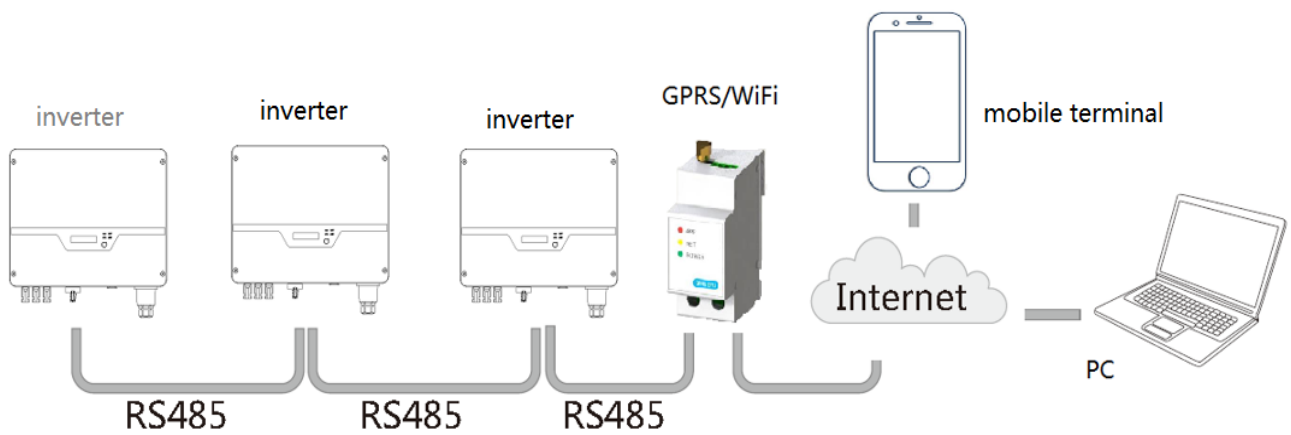

Figure 3-10 RS485 in multiple series

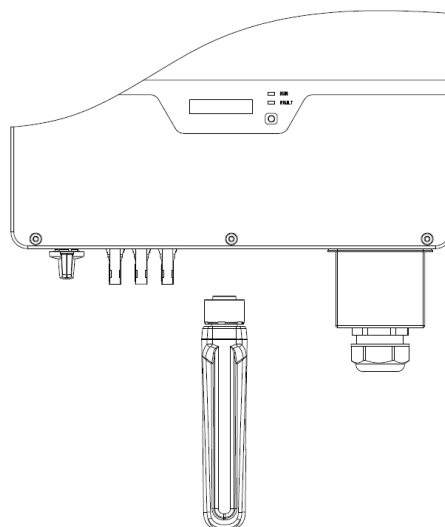

Figure 3-11 install wifi/gprs module

Please refer to the module user manual in detail.

3.6. Starting the Inverter

Before turn on the inverter, please confirm:

- a) Three AC wires (PE/L/N) cable correctly connected to the inverter AC side through AC circuit breaker;
- b) The DC cable connected correctly to the inverter DC side through DC circuit breaker, please be attention to the cable connected to the two string correctly and it's polarity;
- c) The unused terminals are covered.

Starting the inverter:

Step1: Close the DC and AC circuit breaker;

Step2: If the solar panels provide enough energy, the power module will work and the LCD panel will be lit;

Step3: In case you are starting the inverter for the first time, the inverter needs to be commissioned. Commissioning is described on page 17,chapter 4.3

Step4: Then the inverter will turn into self-check mode and the LCD panel will display the remaining time of connect simultaneously;

Step5: After the inverter turn into normal mode, it feed electrical energy into grid, and LCD panel will display the generated electrical energy.

As long as the inverter works, it will automatically track the maximum power point to absorb the maximum energy from solar. When night comes, the irradiance is not strong enough to provide energy, the inverter will power off automatically. When the next day comes, the input voltage reaches the start value, it will start again automatically.

4. User Interface

4.1. Led and Key

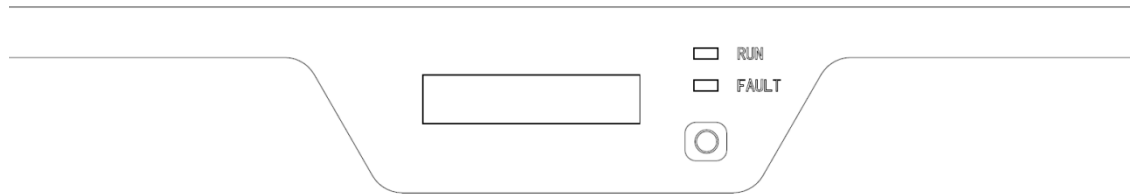

Figure 4-1 LED display

Object	Description
RUN (Green LED)	On = Normal operation
	Flashing = Waiting, checking or starting up
FAULT (Red LED)	On = Failure,
	Flashing = Temporary failure
Pushbutton	Pressing < 1 s: Next
	Pressing > 2 s: Enter

4.2. LCD Display

The LCD display shows parameters of inverters which can be set through Pushbutton.

Pressing < 1 s: Next \longrightarrow

Pressing > 2 s: Enter: \longrightarrow

None (just wait): return \dashrightarrow

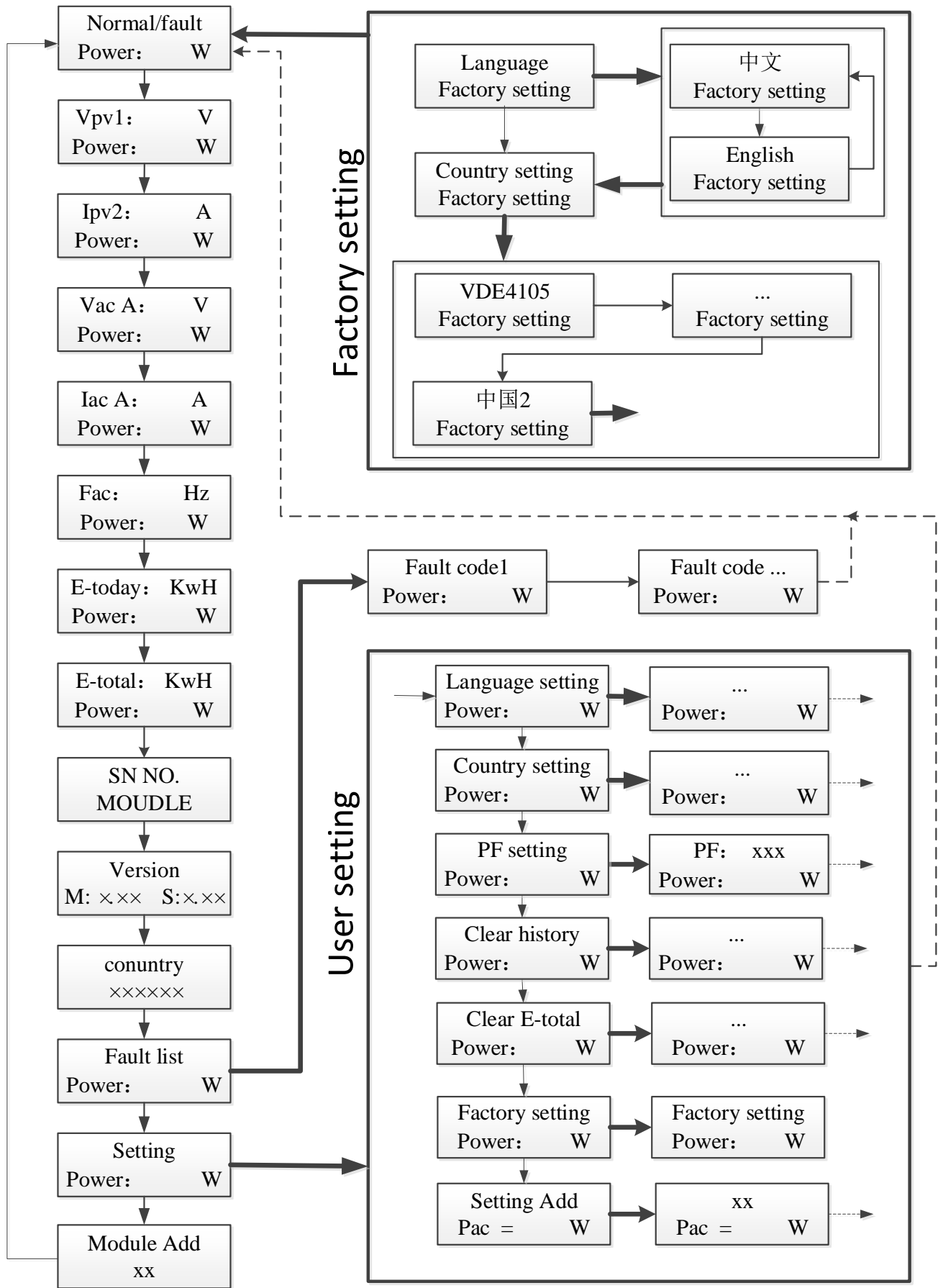

4.3. Factory setting

1. Press pushbutton long in order to enter the “Factory setting” menu
2. Press pushbutton long to enter the “language setting” menu
3. Press pushbutton less than 1 sec. to the language menu you want and Press pushbutton long to select
4. Press pushbutton less than 1 sec. to the country menu you want and Press pushbutton long to select

4.4. Setting language

1. Press pushbutton less than 1 sec. several times until you reach the “Setting” menu
2. Press pushbutton long in order to enter the “setting” menu
3. Press pushbutton less than 1 sec. several times until you reach the “language setting” menu
4. Press pushbutton less than 1 sec. to the language menu you want and Press pushbutton long to select

4.5. Setting modulebus address

1. Press pushbutton less than 1 sec. several times until you reach the “Setting” menu
2. Press pushbutton long in order to enter the “setting” menu
3. Press pushbutton less than 1 sec. several times until you reach the “module add” menu
4. Press pushbutton less than 1 sec. to the modulebus address number you want and Press pushbutton long to set

5. Warranty

The standard warranty period for the inverter is 60 months from the date of installation and no more than 66 months (5.5 years) from the date of shipment from factory.

5.1. Warranty Claim Procedure

Please report defective device with a brief error description and SN code to our service mail or service hotline for registration.

Alternatively, please contact your specific dealer or installer if your unit is defective or faulty.

To claim the warranty under the warranty terms of factory, you need to supply us with the following information and documentation regarding the faulty unit:

In the case of an exchange, the remainder of the warranty entitlement will be transferred to the replacement device. In this event, you will not receive a new certificate, as this replacement will be noted by factory..

5.2. Service after Warranty Expiration

For products which are out of warranty, factory charges an on-site service fee, parts, labor cost and logistic fee to end-user which can be any/all of:

- On-site attendance fee: Cost of travel and time for the technician in attending on-site;
- Parts: Cost of replacement parts (including any shipping/admin fee that may apply);
- Labor: Labor time fee charged for the technician, who is repairing, maintaining, and installing (hardware or software) and debugging the faulty product;
- Logistic fee: Cost of delivery, tariff and other derived expense when defective products are sent from user to factory or/and repaired products are sent from factory to user;

6. Contact Information

If you have any further technical questions about our products, please contact us:

Renacpower Technology Co., Ltd

Address: Building 6, No. 2, West Jinzhi road, High-Tech district, Suzhou city, Jiangsu Province

Email: service@renacpower.com

For further information of Renacpower warranty regulation and reliability, please visit

www.renacpower.com

Appendix A: FAQ (Frequently asked questions)

Sometimes, the PV system does not work normally; we recommend the following solutions for average troubleshooting. This can help the technician to understand the problem and take a proper action.

	LCD display	Possible actions
Clearable Fault	Isolation Fault	<ol style="list-style-type: none"> 1. Check whether the inverter is earthed and test impedance between PV (+) & (-) and the impedance must exceed 3MΩ; 2. Check whether the AC-side has contacts with earth.
	Ground Current Fault	<ol style="list-style-type: none"> 1. The ground current is too high. 2. After cutting off the AC side connection, unplug the inputs from the PV generator and check the peripheral AC system. 3. After the cause is cleared, re-plug the PV panel and AC connection, and check PV inverter status.
	Grid Fault Fac Over Range Vac Over Range	<ol style="list-style-type: none"> 1. Wait for 5 minutes, if the grid returns to normal, PV inverter automatically restarts. 2. Make sure grid voltage and frequency meet the local specifications.
	Utility Loss	<ol style="list-style-type: none"> 1. Grid is not connected. 2. Check grid connection cables. 3. Check grid usability. 4. If grid is ok and the problem exists still, maybe the fuse in the inverter is open, please call service.
	Over Temperature	<ol style="list-style-type: none"> 1. The internal temperature of inverter is higher than specified normal value. 2. Find a way to reduce the ambient temperature. 3. Or move the inverter to a cooler environment.
	PV over Voltage	<ol style="list-style-type: none"> 1. Check the open PV DC voltage, and see if it is greater than or too close to 950VDC 2. If PV DC voltage is less than 950VDC, and the problem still occurs, please call local service.
Permanent Fault	Consistent Fault	Disconnect PV (+) or PV(-) from the input, restart the inverter.
	Relay-Check Fail	<ol style="list-style-type: none"> 1. Disconnect all PV (+) or PV (-). 2. Wait for a few seconds. 3. After the LCD switches off, reconnect and check again. 4. If the problem remains, please call local service.
	DC INJ High	
	EEPROM R/W Fail	
	SCI Failure	
	AC HCT Fault	
	GFCI Failure	

RENAC

Renac Power Technology Co.,Ltd.

www.renacpower.com

Headquarters

Add: Block 6, No.2, West Jinzhi Road, Suzhou National Hi-Tech District, Suzhou, China
Tel: 0512-66677278

Wuxi Office

Add: Floor 16, Building A3, No. 77 of Jiangzhu West Rd, Wuxi, Jiangsu, China
Tel: 0510-85161623
