

RENAC

R1 Baby Series

(NAC1-3K-SS)

NAC1K-SS/NAC1K5-SS/NAC2K-SS

NAC2K5-SS/NAC3K-SS



Renac Power Technology Co.,Ltd.

Copyright Declaration

The copyright of this manual belongs to RENAC Power Technology Co., Ltd. Any corporation or individual should not plagiarize, partially copy or fully copy it (including software, etc.). And no reproduce or distribution of it in any form or by any means.

RENAC Power retains the ownership and reserves the right of final interpretation. This information is subject to changes without notice.

1 Note on this Manual

1.1 Scope of application

This installation guide describes the assembly, installation, commissioning, maintenance and failure search of the following RENAC Power inverters:

NAC1K-SS, NAC1K5-SS, NAC2K-SS, NAC2K5-SS, NAC3K-SS

Store this manual where it will be accessible at all times.

1.2 Target Group

This manual is for qualified personnel. The tasks described in this manual may only be performed by qualified personnel.

1.3 Symbols Used

The following types of safety instructions and general information appear in this document as described below:



Danger :

Danger indicates a hazardous situation which, if not avoided, will result in death or serious injury.



Warning:

Warning indicates a hazardous situation which, if not avoided, could result in death or serious injury.



Caution :

Caution indicates a hazardous situation which, if not avoided, could result in minor or moderate injury.



Note :

Note provides tips that are valuable for the optimal operation of your product.

2 Safety

2.1 Appropriate Usage

The RENAC Power Series is a PV inverter which converts the DC current of a PV generator into AC current

and feeds it into the public grid.

Principle of a PV plant

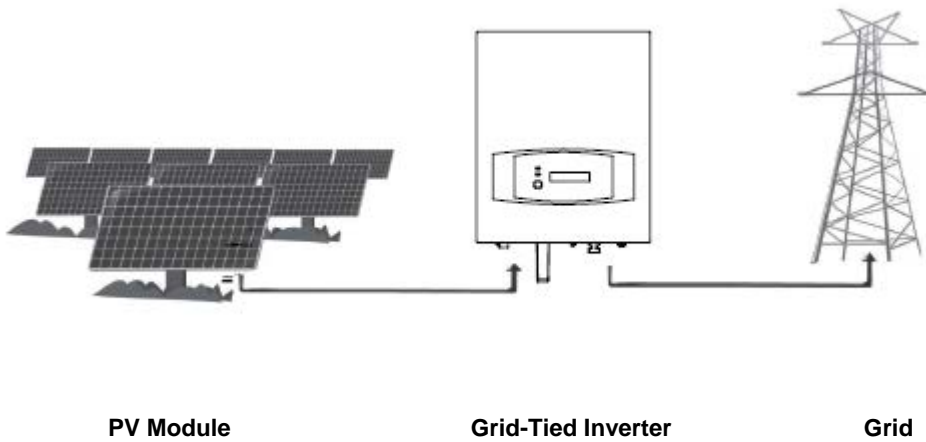

Figure 1 PV Grid-tied System

2.2 Important Safety Instructions



Danger: Danger to life due to high voltages in the inverter!

- All work on the inverter may be carried out by qualified personnel only.
- The appliance is not to be used by children or persons with reduced physical, sensory or mental capabilities, or lack of experience and knowledge, unless they have been given supervision or instruction.
- Children should be supervised to ensure that they do not play with the appliance.



Caution :

Danger of burn injuries due to hot enclosure parts!

During operation, the upper lid of the enclosure and the enclosure body may become hot.

- Only touch the lower enclosure lid during operation.



Caution :

Possible damage to health as a result of the effects of radiation!

- Do not stay closer than 20 cm to the inverter for any length of time.



Note : Grounding the PV generator

Comply with the local requirements for grounding the PV modules and the PV generator. RENAC Power recommends connecting the generator frame and other electrically conductive surfaces in a manner which ensures continuous conduction and ground these in order to have optimal protection of the system and personnel.



2.3 Explanation of Symbols

This section gives an explanation of all the symbols shown on the inverter and on the type label.

2.3.1 Symbols on the Inverter

Symbol	Explanation
	<p>Danger to life due to high voltages in the inverter!</p> <p>There is residual voltage in the inverter. The inverter requires 5 minutes to discharge.</p> <p>Wait 5 minutes before you open the upper lid or the DC lid.</p>

2.3.2 Symbols on the Type Label

Symbol	Explanation
	<p>CE mark.</p> <p>The inverter complies with the requirements of the applicable CE guidelines.</p>
	<p>Beware of hot surface.</p> <p>The inverter can become hot during operation. Avoid contact during operation.</p>

2.3.3 Important Safety Instructions

When using the product, please do remember the below information to avoid the fire, lightning or other personal injury:



Warning:

Ensure input DC voltage $\leq 500V$. Over voltage may cause permanent damage to inverter or other losses, which will not be included in warranty! This chapter contains important safety and operating instructions. Read and keep this Operation Guide for future reference.



Warning:

Authorized service personnel must disconnect both AC and DC power from the RENAC Power inverter before attempting any maintenance or cleaning or working on any circuits connected to the RENAC Power inverter.

1. Before using the RENAC Power inverter, read all instructions and cautionary markings on the RENAC Power inverter, and all appropriate sections of this guide.
2. Use only attachments recommended or sold by RENAC Power. Otherwise it may result in a risk of fire, electric shock, or injury to persons.

3. To avoid a risk of fire and electric shock, make sure that existing wiring is in good condition and that wire is not undersized. Do not operate the RENAC Power inverter with damaged or substandard wiring.
4. Do not disassemble the RENAC Power inverter. It contains no user-serviceable parts. See warranty for instructions on obtaining service. Attempting to service the RENAC Power inverter yourself may result in a risk of electrical shock or fire and will void your warranty.
5. To reduce the risk of electrical shock, authorized service personnel must disconnect both AC and DC power from the RENAC Power inverter before attempting any maintenance or cleaning or working on any circuits connected to the RENAC Power inverter. Turning off controls will not reduce this risk.
6. Keep away from flammable, explosive materials to avoid fire disaster.
7. The installation place should be away from humid or corrosive substance.
8. To avoid electric shock accident, please do not disassemble the inverter because inside of inverter there are high-voltage capacitances installed. Fatal High-voltage will remain in the inverter after its disconnection with grid after 5-10 minutes.
9. To reduce the chance of short-circuits, authorized service personnel must use insulated tools when installing or working with this equipment.

3 Introductions

3.1 Basic Features

The RENAC Power smart inverter is one of the finest inverter on the market today, incorporating state-of-the-art technology, high reliability, and convenient control features.

- Advanced SCM Control technology;
- Utilize the latest high-efficiency power component from IR Company;
- Optimal MPPT technology;
- Advanced Anti-islanding solutions;
- IP65 protection level;
- Efficiency up to 97.2%;
- THD < 2%;
- Safe & Reliable: transformerless design with software and hardware protection;
- Friendly HMI.

- ☆ LED status indications;
- ☆ LCD display technical data, Human-Machine interaction through press key;
- ☆ RS232/WIFI/RS485 communication interface;
- ☆ PC/Mobile remote control.

3.2 Electrical block diagram

3.2.1 Electrical block diagram, please see figure 2.

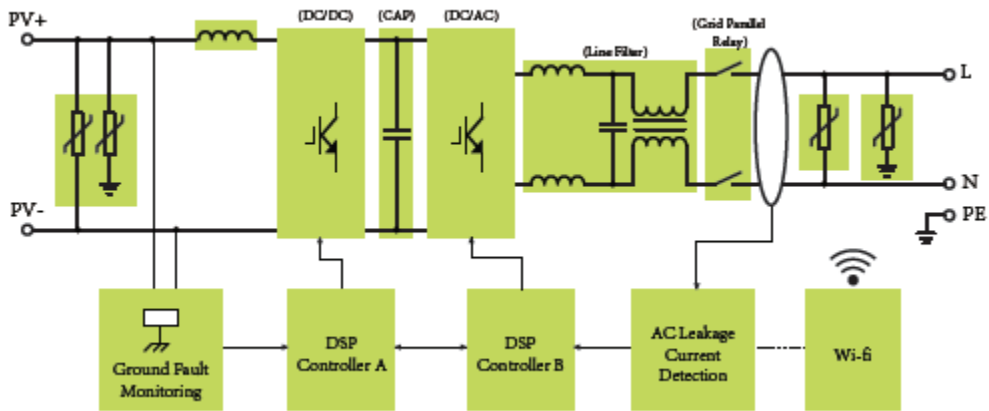

Figure 2 Electrical Block Diagram

3.3.2 Terminals of PV inverter

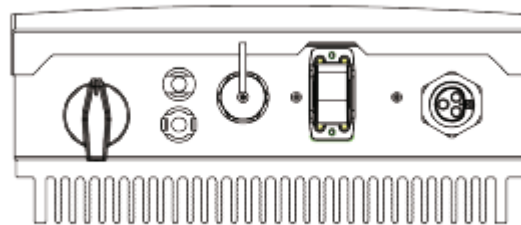

Figure 3 Terminal of PV inverters (NAC1K-SS/NAC1K5/NAC2K-SS/NAC2K5/NAC3K-SS)

3.3 Dimension and Weight

3.3.1 Dimension

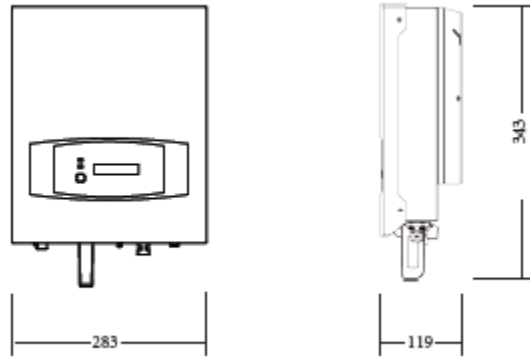

Figure5 (NAC1K-SS/NAC1K5-SS/NAC2K-SS/NAC2K5-SS/NAC3K-SS)

3.3.2 Weight

Table 1 Weight

Model	NAC1K-SS	NAC1K5-SS	NAC2K-SS	NAC2K5-SS	NAC3K-SS
Weight	6.5KG	6.5KG	7KG	8KG	8KG

4 Specifications

4.1 Specifications (NAC1K-SS/NAC1K5-SS/NAC2K-SS/NAC2K5-SS/NAC3K-SS)

4.1.1 DC Input

Model	NAC1K-SS	NAC1K5-SS	NAC2K-SS	NAC2K5-SS	NAC3K-SS
Max.DC Power	1100W	1700W	2250W	3200W	3200W
Max.DC Voltage	500V				
MPPT voltage Range	90-500V				
Start Voltage	150V				
Min. DC Voltage	70V				
No. of MPP Trackers	1				
No. of Input Strings per Tracker	1				
Max. DC Input Current	12.5A	12.5A	12.5A	12.5A	12.5A
Type of DC Connector	MC4				
DC Switch	Optional				

4.1.2 AC Output

Model	NAC1K-SS	NAC1K5-SS	NAC2K-SS	NAC2K5-SS	NAC3K-SS
Rated AC Power	1000W	1500W	2000W	2500W	3000W
Max.output power	1100VA	1650VA	2200VA	2750VA	3200VA
Rated AC Current	4.4A	6.6A	8.7A	10.9A	13.0A
Max. AC Current	4.8A	7.2A	9.6A	12A	14A

Nominal AC Voltage/Range	230V/160-290V
Grid frequency/ range	50HZ/60HZ 45~55HZ/55~65HZ
Power Factor[cos φ]	0.8leading ~0.8lagging (full load)
Total Harmonic Distortion [THDi]	<2%
Number of output phases:	L+N+PE

4.1.3 Efficiency, Safety and Protection

Model	NAC1K-SS	NAC1K5-SS	NAC2K-SS	NAC2K5-SS	NAC3K-SS
Max.Efficiency	97.20%	97.20%	97.20%	97.20%	97.20%
Euro Efficiency	96.40%	96.60%	96.60%	96.60%	96.60%
MPPT Accuracy	>99.9%	>99.9%	>99.9%	>99.9%	>99.9%
Protection					
DC Insulation Monitoring	Integrated				
Input Reverse Polarity Protection	Integrated				
Output Over Current Protection	Integrated				
Anti-island Protection	Integrated				
GFCI Monitoring	Integrated				
OverHeat Protection	Integrated				

4.1.4 General Specification

Model	NAC1K-SS	NAC1K5-SS	NAC2K-SS	NAC2K5-SS	NAC3K-SS
Size(Width*Height*Depth)	283x343x119mm				
Weight	6.5KG	6.5KG	7KG	8KG	8KG
Mounting	Wall Hangings				
User Interface	LCD				
Communication	WIFI				
Ambient Temperature Range	-25 °C~ 60 °C				
Relative Humidity	0-100%(No condensation)				
Operating Altitude	4000m				
Standby Self Consumption	0				
Topology	Transformerless				
Cooling	Natural Convection				
Protection Grades	IP65				
Noise	<30dB				
Warranty	5 year(Standard),10/15/20/25 year(Optional)				

5 Function

Operation Mode

【Stand-by Mode】

The stand-by mode means that the inverter is ready to but still not connect to the grid. Under this mode, it will continue check if PV array has enough power to feedback into grid. When the inverter passes dump load test after startup, it will change from stand-by mode to checking mode.

【Checking Mode】

If inverter passed dump load test and no error/fault occurs, starts checking to deliver power.

【On-Grid Mode】

Under this mode, inverters convert PV array's DC into AC and feedback into grid.

CAUTION:

The inverter decreases the output power is normal in the condition of thermal protection, but if this phenomenon often occurred, you need to check the heatsink, or considering put the inverter in the place where have better air flow. If output power decreases caused by electrical, please ask for professional supports.

【MPPT Mode】

The default setting is MPPT mode, the operation mode will return to MPPT after DC&AC restart. The MPPT voltage range of RENAC Power Inverters NAC1K-SS/NAC2K-SS/NAC3K-SS is 90/180/230V~500V.

【Fault Mode】

If any fault/error occurred, inverter stopped delivering power until the fault/error is clear. Some fault/error will auto recover, and some need manually restart.

【Setting Mode】

The user can get into the setting mode by press "Function" key for 6 seconds if DC is exist.

The detail information please refers to operation method in chapter 7.

6 Installation

6.1 Installation

Attention:

Checking environment where system is installed.

Check whether the installation site does not fall into none of the following conditions:

1. The ambient temperature is outside the range of tolerable ambient temperature (-20°C to +60°C, -4°F to +140°F).
2. Higher than the altitude of about 2,000 m above sea level.
3. Prone to damage by sea water.
4. Close to corrosive gas or liquid (for example, locations where chemicals are processed, feed lots or poultry).
5. Exposed to direct sunlight.
6. Prone to flooding or high levels of snow pack.
7. Minimal or no air flow and high humidity.
8. Condensations.
9. Exposure to steam, vapor, or water.
10. Exposure to direct cool air.
11. Near television antenna or antenna cable.
12. Ventilation is not enough to cool the inverter, that is to say, outdoors, the inverter requires. At least 20 cm (see table 2) of clearance between the bottom of the unit and the ground, indoors, it is recommended that the same clearance between the bottom of the unit and the floor be used. Installing the inverter in the place mentioned above may cause the malfunction of the system caused by water or high temperature inside the inverter. Please let users know that RENAC Power will not compensate the fault caused by the above situations.

Note(for RENAC Power series) :

1. The PV modules should have an IEC61730 Class A rating or equivalent. The resistance between PV positive or negative and ground must be more than 600kohm.
2. This product can cause a dc current in the external protective earthing conductor. Where a residual current-operated protective (RCD) or monitoring (RCM) device is used for protection in a case of direct or indirect contact, only an RCD or RCM of Type B is allowed on the supply side of this product.
3. The installation place should be away from humid or corrosive substance.
4. The RENAC Power inverters can be used outdoor, The pollution level of the external environment is 3.
5. Users can check the firmware version via LCD function as shown below.

- 6. The ISC PV is can be referred as Max DC current.
- 7. The AC output inrush current is 20A with duration time 2us.
- 8. The maximum output fault current of AC output is below 15mA RMS.
- 9. The maximum output over current protection can be referred as Max output current.



Warning: Residual current protection:

Residual current detection and monitoring unit integrated inside, an external residual current breaker is not required.
 If an external RCD or residual current breaker is strictly required, you must use a switch that triggers at a failure current of 300mA or higher.



Warning:

A warning that when the photovoltaic array is exposed to light, it supplies a DC voltage to the PCE.



Warning:

The open voltage of the PV array must be less than 550V.
 Over voltage may cause permanent damage to inverter.



Caution!

Installation shall comply with local regulations and technical rules.
 Installation shall comply with the relevant instructions of EN62109-1/2.

Table 2 Available Space Size

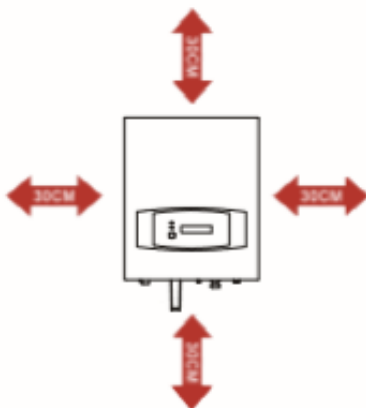

	Min. Size
Side	30CM
Top	30CM
Bottom	30CM
Front	30CM

6.2 Preparation

Below tools are needed before installation:



Warning:

Before installation and maintenance, AC and DC side doesn't carry electricity, but if DC side is just disconnected, capacitance still contains electricity, so please wait for at least 10 minutes to ensure capacitor completely release the energy and inverter is not electrified.



Note:

Inverter should be installed by technician.

6.3 Installation Steps

1. Mark four locations on the wall according to the mounting brackets in the box:

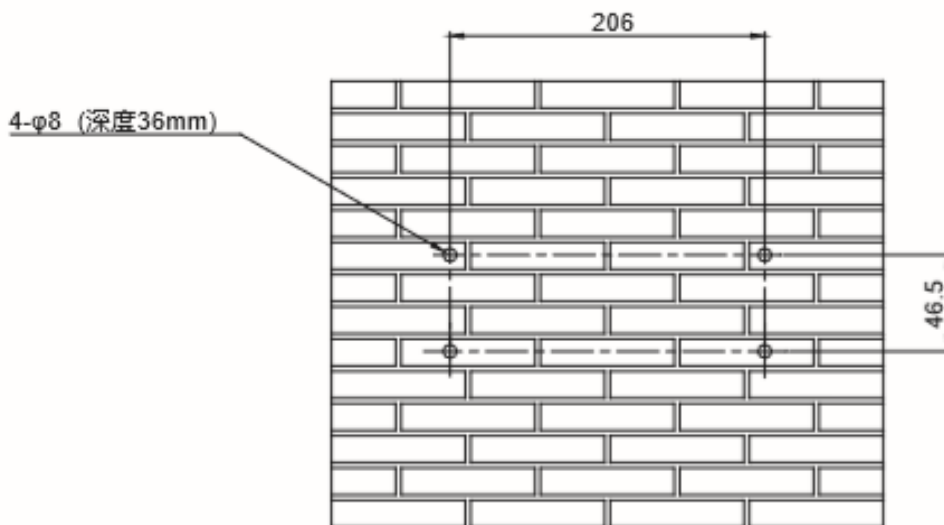

Figure 7 Installation of Expansion Pipe

2. Clean all dust outside/inside the hole and measure pitch-row before installation. It need repositioning and drilling holes if the hole with much error. Then put expansion pipe into the hole vertically, use rubber hammer

tap pipe into the wall completely. After that, twist 4 screws into corresponding pipes.

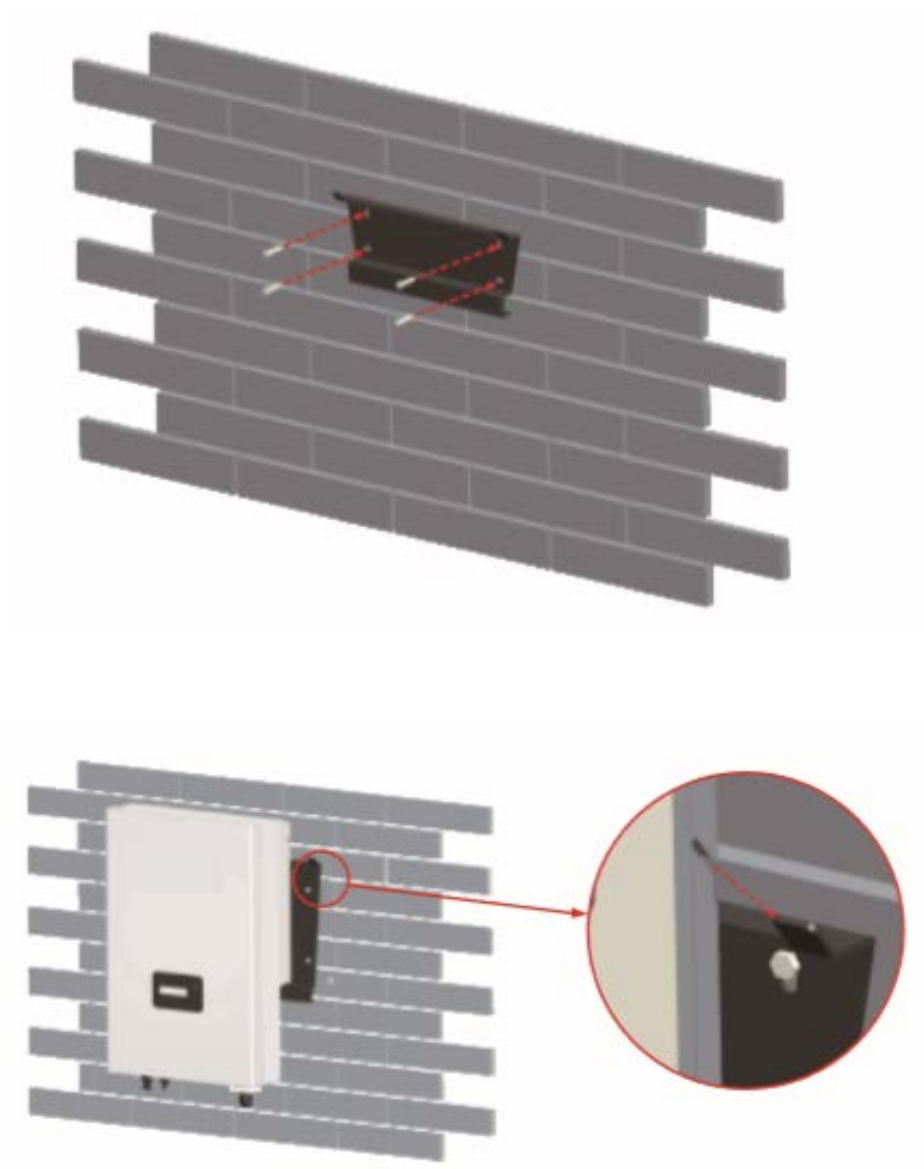

Figure 8 Bracket & Inverter Installation

3. Use the bracket to install the inverter onto the narrow vertical panel (or wall). Put upper-part holes of the inverter onto the bracket. (See figure 8).



Figure 9 Fix the inverter

4. Use M4 screw to fix the bottom of the inverter. (See figure 9).
5. Complete the installation process.

6.4 Connections of the PV power system

(1) NAC (1K-SS/1K5-SS/2K-SS/2K5-SS/3K-SS) can be connected to 1-strings PV modules. Please select PV modules with excellent function and reliable quality. Open-circuit voltage of module arrays connected in series should be $<$ Max. DC (Table 3) input voltage; operating voltage should be conformed to MPPT voltage range.

Table 3 DC Voltage Limitation

Max. DC Voltage	500V (DC)
-----------------	-----------

Please use PV cable to connect modules to inverter. From junction box to inverter, voltage drop is about 1-2%. So we suggest the inverter install near PV module, in order to save cable and reduce DC loss.

Note: Check polarity of module array, Max. Voltage connected in series is 500V (DC).

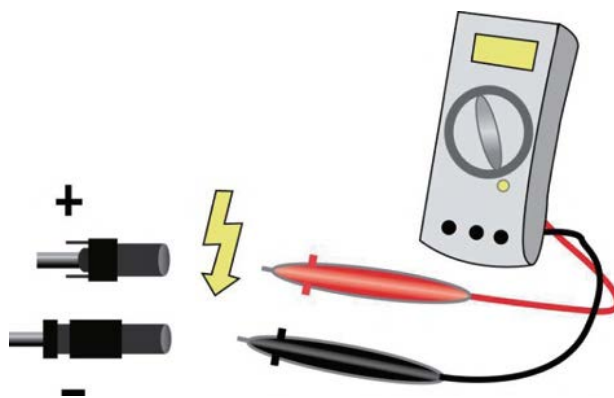

Figure 10 Use multimeter to measure module array voltage

Warning:

PV module voltage is very high which belongs to dangerous voltage range, please comply with electric safety rules when connecting.



Warning:

When there is something wrong with module arrays, modules can be connected with PV grid-tied inverter only after eliminating these problems.

(2) AC Output

NAC (K-SS/1K5-SS/2K-SS/2K5-SS/3K-SS) are designed for single phase grid. Voltage range is from 160V to 290V, frequency is 45 ~ 55Hz/55 ~ 65Hz. Other technical requests should comply with the requirement of local public grid.

Table 4 Cable Requirement

Model	NAC1K-SS	NAC1K5-SS	NAC2K-SS	NAC2K5-SS	NAC3K-SS
Cable Requirement	4mm ²	4mm ²	4mm ²	4mm ²	4mm ²
Breaker	16A	20A	25A	25A	25A

Breaker should be installed between inverter and grid; any load should not connect with inverter directly.

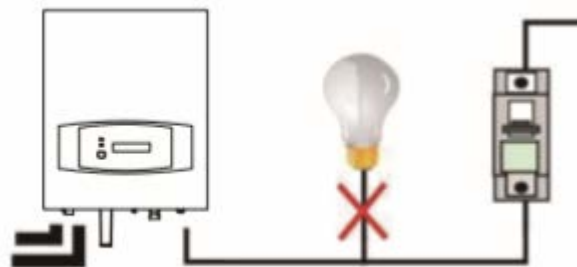

Figure 11 Incorrect Connections between Load and Inverter

Impedance of RENAC Power inverter AC connecting dot should be less than 2Ω. To ensure reliable anti-islanding function, PV cable should be used to ensure wire loss < 1% than normal power. Moreover, length between AC side and grid connecting dot should be less than 150m. Below chart is cable length, section area and wire loss:

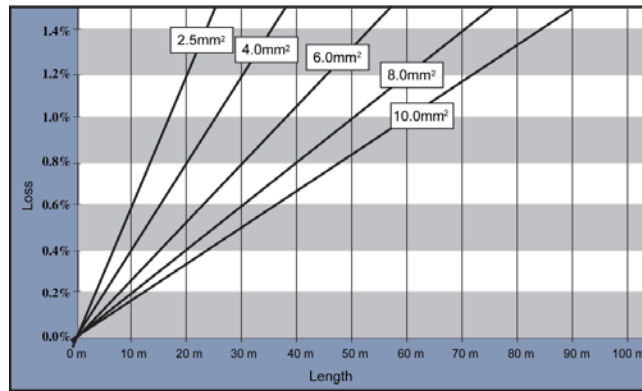
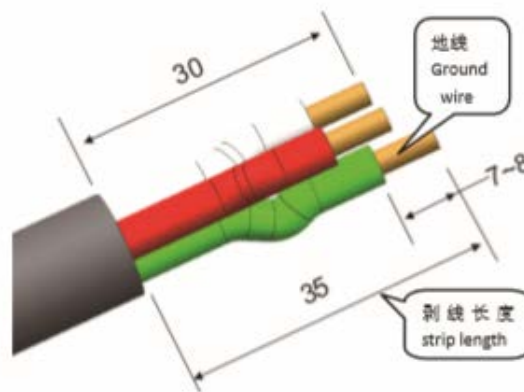

Figure 12 AC Cable Loss

This product has AC waterproof connector parts. You have to wire AC by yourself. Please see figure 13 and 15 for AC connector assembling guide:

6.5 Female connector assembly instruction

6.5.1 Only supports multiple strands of copper wire. Cut and strip the wire as required, in which the grounding wire should be 5mm more than the zero wire and the fire wire, and the stripping length should be 7~8mm.



6.5.2 Unscrew the tail assembly (nut, tensioner, sealing plug) from the female component and pass the stripped wire through the back to the front.



6.5.3 Crimp the wires and insert the cable core wires into the terminals correctly. Screw the wire tightly, and then pull the wire in reverse (10N force) to verify the crimping effect. Screw torque $0.8 \pm 0.1 \text{ N}\cdot\text{m}$. Be careful not to damage the terminals and the terminal lock. After crimping, the tensile strength should meet the requirements of the following table:

Conductor cross-section area (mm ²)	Required tensile strength (N)
2.5	>50
4.0	>60

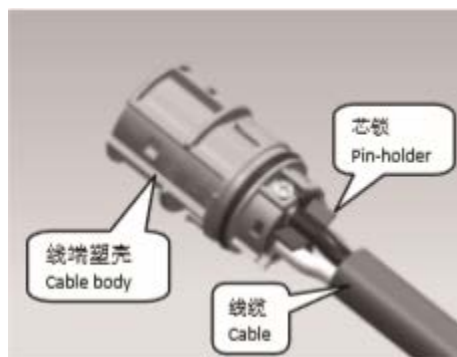

6.5.4 Press the wire end molded case into the female housing correctly according to the position of the card slot, and press it to the position to hear a crisp “click” sound.

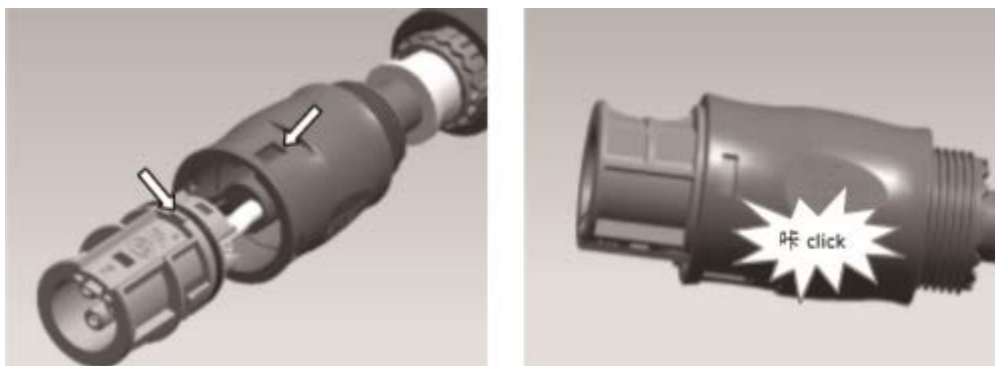

6.5.6 Push the sealing plug and the tensioner into the cavity at the rear of the casing, and then tighten the nut with a torque of $4.0 \pm 0.5 \text{ N}\cdot\text{m}$.



6.6 Connector using instruction

6.6.1 Please cut off the power before use and verify that the male and female are the same model.:

6.6.2 When the male and female connectors are connected, the snaps on the male head are aligned with the grooves on the female head, and a crisp sound is heard when the joint is in place.



Figure15

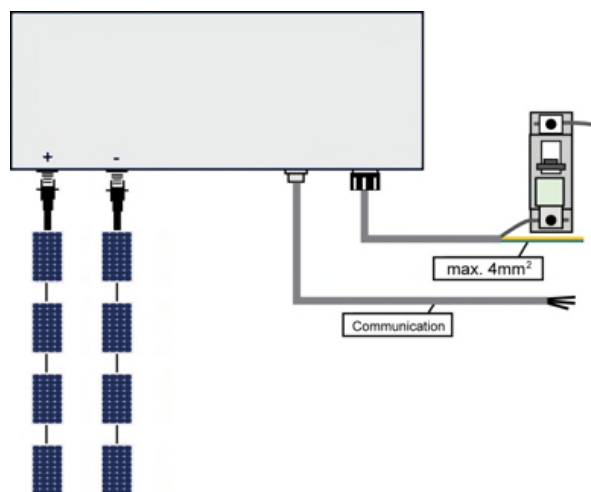

Figure 16 Complete AC connector installation process

6.7 Run the inverter

6.7.1 Start inverter after checking all below steps:

- a. Make sure all the DC breaker and AC breaker are disconnect;
- b. AC cable is connected to grid correctly;
- c. All PV panels are connected to inverter correctly; DC connectors which not used should sealed by cover.

6.7.2 Start inverter:

- a. Turn on DC and AC side switches;
- b. Inverter will start up automatically when PV panels generate enough energy. Below is three different states when operating, which means inverter starting up successfully.

Waiting: Inverter is waiting to checking when output DC voltage from PV panels is greater than 70V (lowest start-up voltage) but less than 150V (lowest operating voltage) (except 1KW inverter, The1KW inverter’s lowest start-up voltage is 120V).

Checking: Inverter will check output environment automatically when DC output voltage of PV panels exceeds 150V (except 1KW inverter, the 1KW inverter’s lowest start-up voltage is 120V) and PV panels have enough energy to start inverter.

Normal: Inverter begins to operate normally with green light on. Meanwhile, feedback energy to grid, LCD displays present output power.

Inverters will work in MPPT mode when PV voltage range is 150 ~500V, inverter will stop feedbacks power to grid when PV power is not enough.



Note : If inverter shows “Fault” Status, please refer to Part 9.

If inverter shows “**Fault**” status, please refer to Part 9.

7 Operation Method

7.1 Control Panel

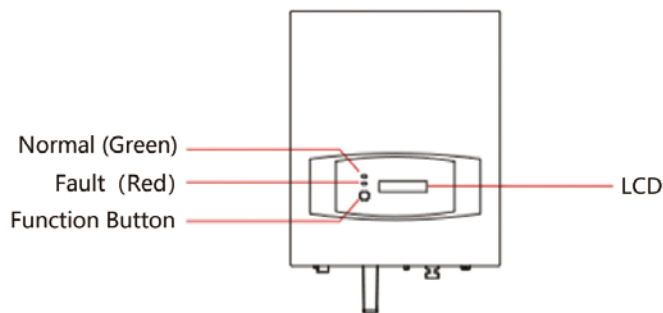

Figure 17 Control Panel

Normal (green) : The inverter is working in normal state;

Fault (red) : The system is in fault state ;

Function key : To check the operating data, detailed usage see section 7.2.

7.2 LCD Function

The system operation interface can be switched by a single button cycle, for a total of 10 operation interfaces, which are described in detail below. In the 1-8 interface, the long button will enter the lock interface, as shown in the figure below. Release the long button to return to the original interface and extend the backlight time under the modified interface. Long key function keys are added to the 9th interface and the 10th interface, which are described in detail below.

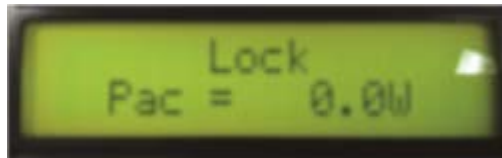

1-1 System operation interface 1: First interface

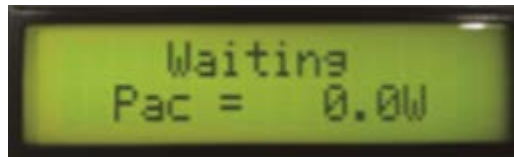

In this interface, the displayed "Waiting" is a change in the state of the system operation, and the working status of the system includes:

1. Waiting state: "Waiting" is displayed.
2. Detection status: "Checking XXXS" is displayed, and XXX refers to the countdown number, which will be displayed as 1-3 digits.
3. Reconnect status: "Reconnect XXXS" is displayed, and XXX refers to the countdown number, which will be displayed as 1-3 digits.
4. Normal operation status: "Normal" is displayed. In this state, the machine is connected to the grid for power generation.
5. Fault Status: Displays the fault description. If there is communication error it will show "SCI Failure".

The displayed "Pac = 0.0W" is the output power of the inverter currently operating.

1-2 System operation interface 2: Energy information interface

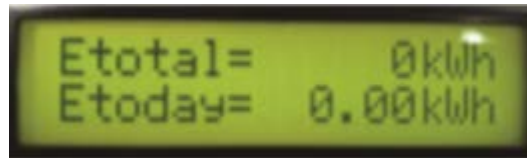

This interface shows that “Etotal” is the current total power generation of the inverter, and “Etoday” is the amount of power generated by the inverter that day.

1-3 System operation interface 3: Input PV1 information interface

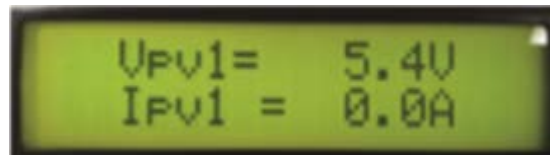

This interface shows the input voltage and current of the first PV input component.

1-4 System operation interface 4: Input PV2 information interface

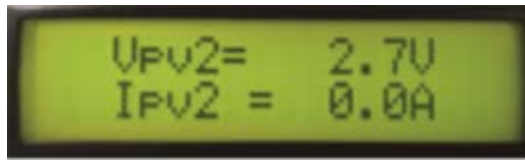

This interface shows the input voltage and current of the second PV input component.

1-5 System operation interface 5: Output grid voltage and current interface

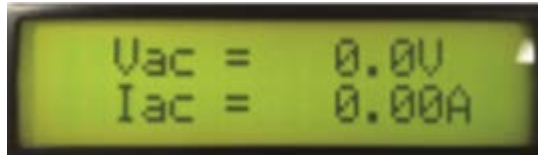

1-6 System operation interface 6: Output grid frequency interface

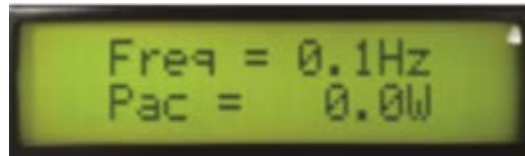

1-7 System operation interface 7: WIFI information interface



This interface displays information about the WIFI module including the WIFI SN number and IP address.

1-8 System operation interface 8: Inverter information interface1

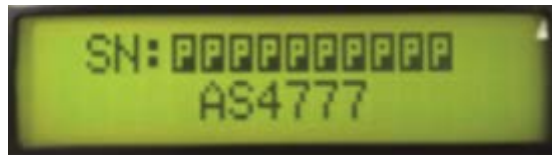

This screen displays the serial number of the inverter and the default on-grid safety.

1-9 System operation interface 9: inverter information interface2

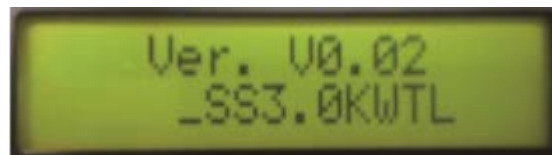

This interface shows the software version of the inverter and the inverter model. Long press the button on the interface to enter the historical fault interface. Pressing and holding the long button is not loose, and the last 3 faults are displayed alternately in the first line of the display with the version time of the software.

1-10 System operation interface 10: Setting interface

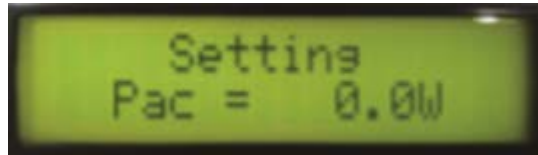

Long press the button under the interface to enter the setting sub-interface. In the setting sub-interface, the setting items are selected by a single button cycle.

1) Set sub-interface 1: WIFI reset settings

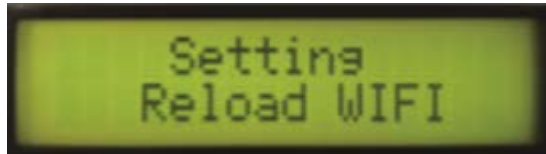

Long press the button of this interface enters the WIFI reset confirmation interface. As shown below:

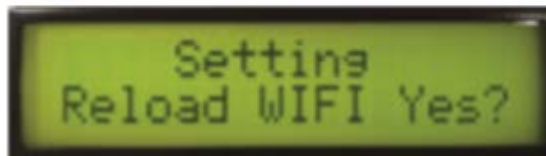
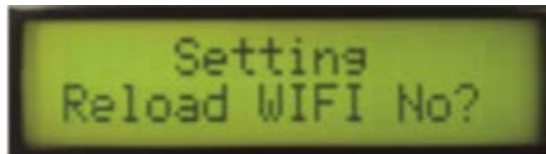

After a single button is pressed to the "Yes" interface, the WIFI reset state is entered. Wait for the reset result.

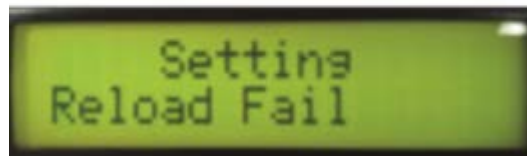
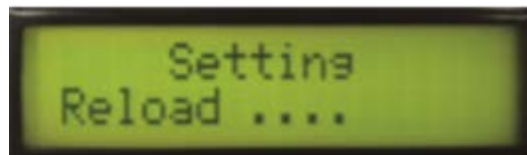

In the reset result interface, single press the button returns to the setting sub-interface, or waits until the system returns to the main interface by default.

2) Set sub-interface 2: Insulation impedance enable setting



Long press the button on the interface enters the insulation impedance enable option.



Single press the button to select Enable (Enable) or Disable (Disable), and long press the button to complete the setting. The following figure shows the setting result. In the setting result interface, single press the button to return to the setting sub-interface, or waits until the system returns to the main interface by default.

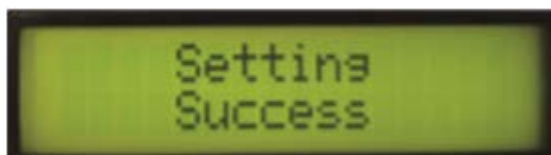

3) Set sub-interface 3: Grid security settings

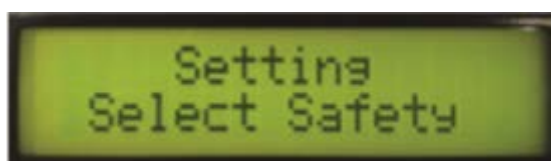

In this interface, long press the button to enter the security setting interface. You need to enter the manufacturer password before setting the security, as shown below:

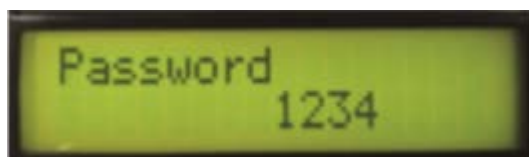

The password is 4 digits. The default is "1234". Long press the button from left to right to switch the password bit. The digit on the setting digit flashes. The valid password on the digit is selected by single press button loop 0- 6, the last digit is selected after the password is selected by long press the button to enter. Enter the wrong password to display the error ID and return to the first re-enter. If the input is correct, it will enter the safety selection page.

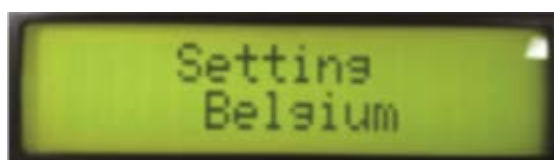

Select the safety code to be set by single press the button, and long press the button to complete the setting according to the rules. The setting results are as follows:



In the result interface, single press the button to return to the setting sub-interface, or wait until the system returns to the main interface by default.

4) Set sub-interface 4: Grid voltage upper limit setting

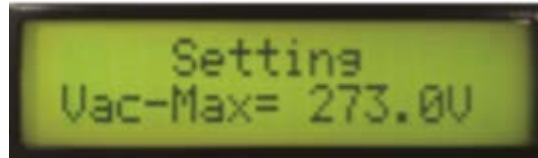

Long press the button on this interface to enter the grid voltage upper limit setting, and "=" flashes. The setting is completed by setting the button to a given voltage with single press the button. In the result interface, single press the button to return to the setting sub-interface, or wait until the system returns to the main interface by default.

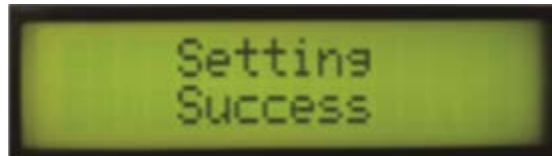

5) Set sub-interface 5: Grid voltage lower limit setting

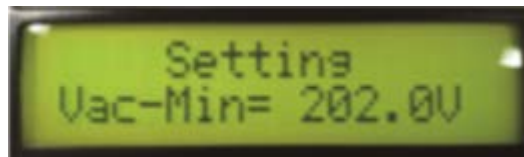

The setting method is the same as the grid voltage upper limit setting.

6) Set sub-interface 6: Grid frequency upper limit setting

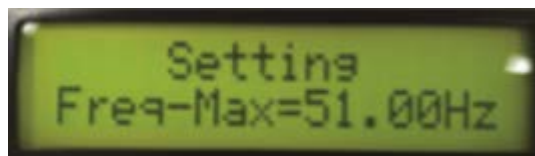

The setting method is the same as the grid voltage upper limit setting.

7) Set sub-interface 7: Grid frequency lower limit setting

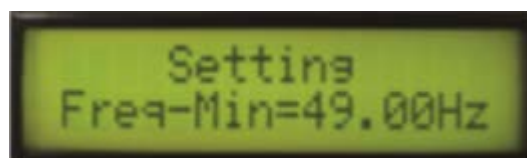

8) Set sub-interface 8: Set the day's power generation to zero

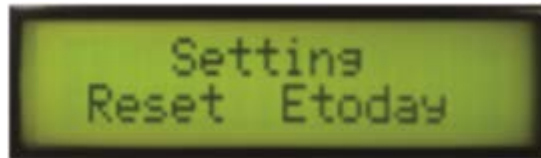

In this interface, long press the button to enter the clear confirmation interface, and single press the button to select the “Yes” long button to complete the setting.

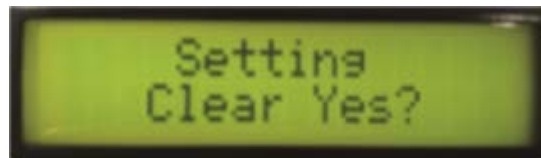

In the result interface, single press the button to return to the setting sub-interface, or wait until the system returns to the main interface by default.

9) Set sub-interface 9: Restore default settings

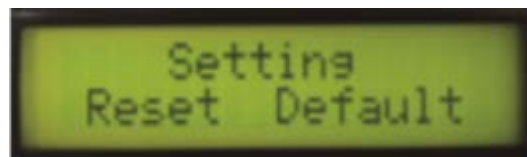

In this interface, long press the button to enter the setting. This setting needs to input the manufacturer password. The method is the same as the password input in the safety setting.

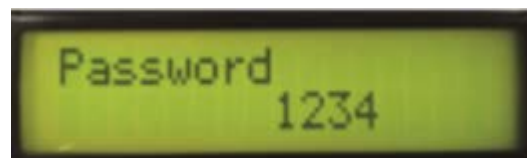

Enter the correct password then enter the restore default settings.

8 Troubleshooting

This section contains information and procedures for solving possible problems with the RENAC Power inverters, and provides you with trouble shooting tips to identify and solve most problem that can occur with the RENAC Power inverters.

This section will help you narrow down the source of any problem you may encounter. Please read the

following troubleshooting steps:

1. Check for a Warning or Fault message on the System Control Panel or a Fault code on the inverter information panel. If a message is displayed, record it before doing anything further.
2. Attempt the solution indicated in Table 8.
3. If your inverter information panel is not displaying a Fault light, check the following list to make sure that the present state of the installation allows proper operation of the unit:
 - (1) Is the inverter located in a clean, dry, adequately ventilated place?
 - (2) Have the DC input breakers opened?
 - (3) Are the cables adequately sized and short enough?
 - (4) Are the input and output connections and wiring in good condition?
 - (5) Are the configurations settings correct for your particular installation?
 - (6) Are the display panel and the communications cable properly connected and undamaged?

Contact RENAC Power Customer Service for further assistance. Please be prepared to describe details of your system installation and provide the model and serial number of the unit.

Table 8 Troubleshooting list

Faults	Diagnosis and Solutions
Grid Faults	1 Waiting for one minute, grid will go back to normal working state. 2 Making sure that grid voltage and frequency complies with standards. 3 Or, please seek for help from us.
No Utility	1 Off to grid. 2 Please check grid-connection, like wire, interface, etc. 3 Checking grid usability. 4 Or seek for help from us.
PV Over Voltage	1 Checking the battery panel's open-circuit voltage whether the value is similar or already >500Vdc. 2 Please seek help from us when voltage ≤500Vdc.

Over Temperature	<p>1 Inner temperature is higher than the set value.</p> <p>2 Lower the surrounding temperature by proper methods.</p> <p>3 Or move the equipment to a cooler location.</p> <p>4 Or seek for help from us.</p>
Over Percentage of DC	<p>1 Output DC current is higher than the set value.</p> <p>2 Wait for one minute.</p> <p>3 Please seek for help from us if it does not go back to normal state.</p>
String Array Communication Fault	<p>1 Disconnect PV (+) , PV (-) with DC, and reconnect them.</p> <p>2 Please seek for help from us if it can not go back to normal state.</p>
Isolation Fault	<p>1 Check the impedance among PV (+)、PV (-) and ground.</p> <p>Impedance should be >2Mohm.</p> <p>2 Please seek for help from us if it can not be detected or the impedance is <2Mohm.</p>
Consistent Fault	<p>1 Disconnect the PV (+), PV (-) with DC input, then reconnect them.</p> <p>2 Please seek for help from us if it can not go back to normal state.</p>
Relay Fault	<p>1 Disconnect the PV (+), PV (-) with DC input, then reconnect them.</p> <p>2 Please seek for help from us if it can not go back to normal state.</p>
Leakage Current Fault	<p>1 Leakage current is too high.</p> <p>2 Disconnect DC and AC connector, check the surrounding equipment on the AC side.</p> <p>3 Reconnect the input connector and check the state of inverter after troubleshooting.</p> <p>4 Please seek for help from us if it can not go back to normal state.</p>
Invalid EEPROM	<p>1 Disconnect the PV (+), PV (-) with DC input, then reconnect them.</p> <p>2 Please seek for help from us if it can not go back to normal state.</p>

Power Pressure on the Bus is too high	1 Disconnect the PV (+), PV (-) with DC input, then reconnect them. 2 Check L line and N line to see whether it has connection faults. 3 Please seek for help from us when this fault happens.
Under Voltage on the Bus	1 Disconnect the PV (+), PV (-) with DC input, then reconnect them. 2 Please seek for help from us if it can not go back to normal state.
Refer to 2.5V Voltage Fault	
GFCI Failure	

9 Decommissioning

9.1 Dismantling the Inverter

1. Disconnect the inverter from DC input and AC output;
2. Remove all connection cables from the inverter.
3. Remove the inverter from the bracket.

9.2 Packaging

If possible, please pack the inverter in the original packaging.

If this is no longer available, you can also use an equivalent carton that fulfills the following requirements:

- Suitable for loads of at least 25 kg
- With handle system
- Can be closed fully

9.3 Storage

Store the inverter in a dry place where ambient temperatures are always between -20 °C and +60 °C.

9.4 Disposal

Please be sure to deliver waste inverters and packing materials to certain site, which could assist relevant department to dispose and recycle.

Warranty and Return Information

Warranty

What does this warranty cover?

This Limited Warranty is provided by RENAC Power and covers defects in workmanship and materials in your RENAC Power PV inverter. This warranty period lasts for five years from the date of purchase at the point of sale to you, the original end user customer. You will be required to demonstrate proof of purchase to make warranty claims.

This Limited Warranty is transferable to subsequent owners but only for the unexpired portion of the Warranty Period. Subsequent owners also require original proof of purchase as described in “What proof of purchase is required?”

What will RENAC Power do?

RENAC Power will, at its option, repair or replace the defective product free of charge, provided that you notify RENAC Power of the product defect within the Warranty Period, and provided that RENAC Power through inspection establishes the existence of such a defect and that it is covered by this Limited Warranty.

RENAC Power will, at its option, use new and/or reconditioned parts in performing warranty repair and building replacement products. RENAC Power reserves the right to use parts or products of original or improved design in the repair or replacement. If RENAC Power repairs or replaces a product, its warranty continues for the remaining portion of the original Warranty Period or 90 days from the date of the return shipment to the customer, whichever is greater. All replaced products and all parts removed from repaired products become the property of RENAC Power.

What proof of purchase is required?

In any warranty claim, dated proof of purchase must accompany the product and the product must not have been disassembled or modified without prior written authorization by RENAC Power. Proof of purchase may be in any one of the following forms:

- The dated purchase receipt from the original purchase of the product at point of sale to the end user, or
- The dated dealer invoice or purchase receipt showing original equipment manufacturer (OEM) status, or
- The dated invoice or purchase receipt showing the product exchanged under warranty

What does this warranty not cover?

This Limited Warranty does not cover normal wear and tear of the product or costs related to the removal,

installation, or troubleshooting of the customer's electrical systems. This warranty does not apply to and RENAC Power will not be responsible for any defect in or damage to:

- a) The product if it has been misused, neglected, improperly installed, physically damaged or altered, either internally or externally, or damaged from improper use or use in an unsuitable environment;
- b) The product if it has been subjected to fire, generalized corrosion, biological infestations, or input voltage that creates operating conditions beyond the maximum or minimum limits listed in the RENAC Power product specifications including high input voltage from lightning strikes;
- c) The product if repairs have been done to it other than by RENAC Power or its authorized service centers;
- d) The product if it is used as a component part of a product expressly warranted by another manufacturer;
- e) The product if its original identification (trade-mark, serial number) markings have been defaced, altered, or removed.

9.5 Return Material Authorization Policy

Before returning a product directly to RENAC Power you must obtain a Return Material Authorization (RMA) number and the correct factory "Ship To" address. Products must also be shipped prepaid. Product shipments will be refused and returned at your expense if they are unauthorized, returned without an RMA number clearly marked on the outside of the shipping box, if they are shipped collect, or if they are shipped to the wrong location.

When you contact RENAC Power to obtain service, please have your instruction manual ready for reference and be prepared to supply:

- The serial number of your product
- Information about the installation and use of the unit
- Information about the failure and/or reason for the return
- A copy of your dated proof of purchase

9.6 Return Procedure

1. Package the unit safely, preferably using the original box and packing materials. Please ensure that your product is shipped fully insured in the original packaging or equivalent.

This warranty will not apply where the product is damaged due to improper packaging.

2. Include the following:

- The RMA number supplied by RENAC Power clearly marked on the outside of the box.
- A return address where the unit can be shipped. Post office boxes are not acceptable.
- A contact telephone number where you can be reached during work hours.
- A brief description of the problem.

3. Ship the unit prepaid to the address provided by your RENAC Power customer service representative.

In addition to the above, you must include return freight funds and are fully responsible for all documents, duties, tariffs, and deposits.

If you are returning a product to a RENAC Power Authorized Service Center (ASC), a RENAC Power return material authorization (RMA) number is not required. However, you must contact the ASC prior to returning the product or presenting the unit to verify any return procedures that may apply to that particular facility and that the ASC repairs this particular RENAC Power product.

9.7 Out of Warranty Service

If the warranty period for your RENAC Power PV inverter has expired, if the unit was damaged by misuse or incorrect installation, if other conditions of the warranty have not been met, or if no dated proof of purchase is available, your unit may be serviced or replaced for a flat fee.

To return your RENAC Power PV inverter for out of warranty service, contact RENAC Power Customer Service for a Return Material Authorization (RMA) number and follow the other steps outlined in “Return Procedure”.

Payment options such as credit card or money order will be explained by the Customer Service Representative. In cases where the minimum flat fee does not apply, as with incomplete units or units with excessive damage, an additional fee will be charged. If applicable, you will be contacted by Customer Service once your unit has been received.

9.8 How do you get service? If your product requires troubleshooting or warranty service, contact your merchant. If you are unable to contact your merchant, or the merchant is unable to provide service, contact Renac Power directly at :

Telephone: 0086 (0) 512-66677278

E-mail: service@renacpower.com

Ver:01

RENAC

Renac Power Technology Co.,Ltd.

www.renacpower.com

Headquarters

Add: Block 6, No.2, West Jinzhi Road, Suzhou National Hi-Tech District, Suzhou, China
Tel: 0512-66677278

Wuxi Office

Add: Floor 16, Building A3, No. 77 of Jiangzhu West Rd, Wuxi, Jiangsu, China
Tel: 0510-85161623
