

# R3 Pro Series

( NAC20-33K-DT )

NAC20K-DT/NAC25K-DT

NAC30K-DT/NAC33K-DT



# Contents

1. Introduction .....	
1.1. Introduction .....	3
1.2. Applied Designations .....	3
1.3. Important Safety Information .....	3
1.4. System Sizing .....	4
2. Technical Description of Inverters .....	5
2.1. Mechanical design.....	5
2.2. Electrical system design .....	6
2.3. Technical data.....	6
3. Installation and startup.....	8
3.1. Package information.....	8
3.2. Installation environment.....	8
3.3. Installation Position.....	9
3.4. Mounting Procedure.....	10
3.5. Electrical connection.....	11
3.5.1. Connection to the grid (AC output).....	11
3.5.2. Connection to PV string (DC input).....	13
3.5.3. RS485 Communication.....	13
3.6. Starting the Inverter.....	16
4. User Interface .....	17
4.1. Led and Key.....	17
4.2. LCD Display.....	17
4.3. Factory setting .....	19
4.4. Setting language.....	22
4.5. Setting modulebus address .....	22
5. Warranty.....	23
5.1. Warranty Claim Procedure .....	23
5.2. Service after Warranty Expiration .....	24
6. Contact Information.....	25
Appendix A: FAQ (Frequently asked questions) .....	26

# Copyright Declaration

The copyright of this manual belongs to Renacpower Co., Ltd.. Any corporation or individual should not plagiarize, partially copy or fully copy it (including software, etc.), and no reproduction or distribution of it in any form or by any means. All rights reserved. Renacpower reserves the right of final interpretation. This manual is subject to change according to user's or customer's feedback. Please check latest version at: <http://www.renacpower.com>.

# 1. Introduction

---

## 1.1. Introduction

---

This manual describes solar inverters:

NAC20K-DT/NAC25K-DT/NAC30K-DT/NAC33K-DT.



These inverters are transformerless based inverter.

Please read the safety instructions in this manual first. Throughout the manual it is assumed that the reader is familiar with AC and DC installations and knows the rules and regulations for electrical equipment and for connecting it to the utility AC grid. It is especially important to be familiar with the general safety rules for working with electrical equipment.

## 1.2. Applied Designations

---

Throughout the manual important information is shown at different levels depending on the character of the information, as shown here:

	Safety information important for human safety. Violation of warnings may result in injury to persons or death.
	Information important for the protection of property. Violation of this type of information may cause damage and loss of property.
	Useful additional information or "Tips and Tricks" on specific subjects.

## 1.3. Important Safety Information

---

Read this before installing, operating or maintaining the inverter.

	<p><b>Before installation:</b></p> <p>Check for damage to inverter and packaging. If you are in doubt, please contact your supplier before installing the inverter. Check the voltages of the solar modules and make sure they are within the limits of the inverter specifications before connecting them to the inverter.</p> <p><b>Installation:</b></p> <p>Only trained and authorized personnel familiar with local electrical codes may install the inverter. For optimum safety, please follow the steps described in this manual. Keep in mind that the inverter has two voltage carrying sides, the PV input and the AC grid.</p> <p><b>Disconnecting the inverter:</b></p> <p>Always disconnect the AC line first! Afterwards disconnect the PV lines. Note that the inverter can still be charged with very high voltages at hazardous levels even when it is disconnected from grid and solar modules. Wait at least 5 min. before proceeding, after having disconnected from grid and PV panels.</p>
---	---

***operating the inverter:***

Before connecting the AC grid to the inverter, make sure that the installation cover is mounted again. The inverter must not be open during operation.

***Maintenance and modification:***

Only authorized personnel are allowed to repair or modify the inverter. To ensure optimum safety for user and environment, only the original spare parts available from your supplier should be used.

***Functional safety parameters:***

Unauthorized changes of functional safety parameters may cause injury or accidents to people or inverter. Additionally it will lead to the cancelling of all inverter operating approval certificates.

## **1.4. System Sizing**

---



When dimensioning a photovoltaic system, it must be ensured that the open circuit voltage of the PV string never exceeds the maximum permissible input voltage of 1000V DC. The PV string open circuit voltage during parallel string operation is 950V. Higher voltages may result in permanent damage to the inverter.

The selection of PV string output should be based on the optimum utilization of the invested capital compared to the expected annual energy yield from the system. This optimization depends on local weather conditions and should be considered in each individual case.

The inverter incorporates an input power limiting device, which automatically keeps the power at levels that are safe for the inverter. The limitation depends mainly on internal and ambient temperatures. The limitation is calculated continuously and always allows the maximum possible amount of energy to be produced.

Please use the tool supplied by Renacpower when dimensioning a photovoltaic system.

## 2. Technical Description of Inverters

### 2.1. Mechanical design

Figure 2-1 shows the outline dimensions of NAC20K-DT/NAC25K-DT/NAC30K-DT/NAC33K-DT.

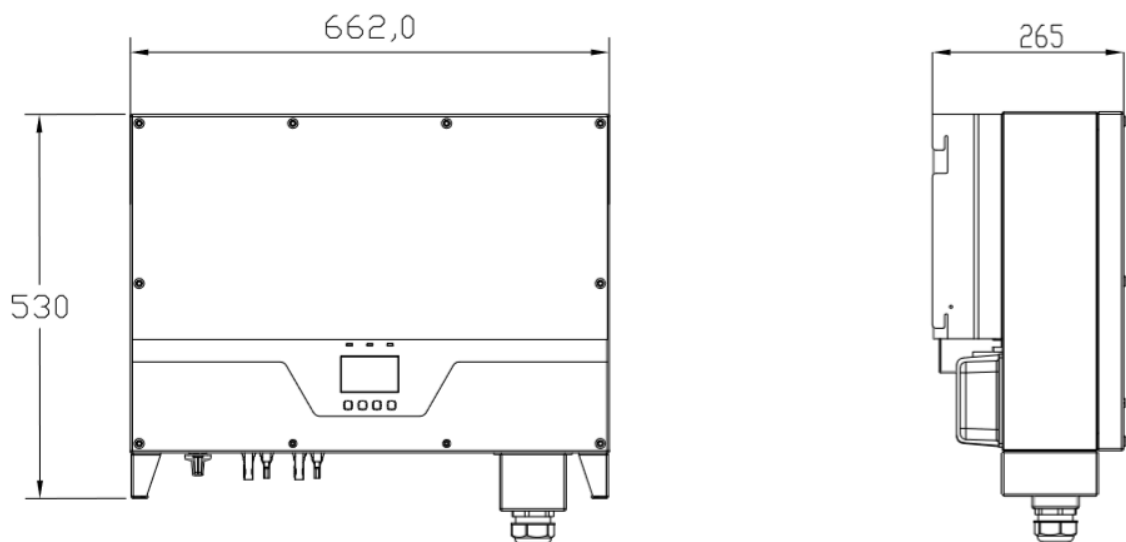

Figure 2-1 Outline dimensions

Figure 2-2 shows the electrical terminals of NAC20K-DT/NAC25K-DT/NAC30K-DT/NAC33K-DT.

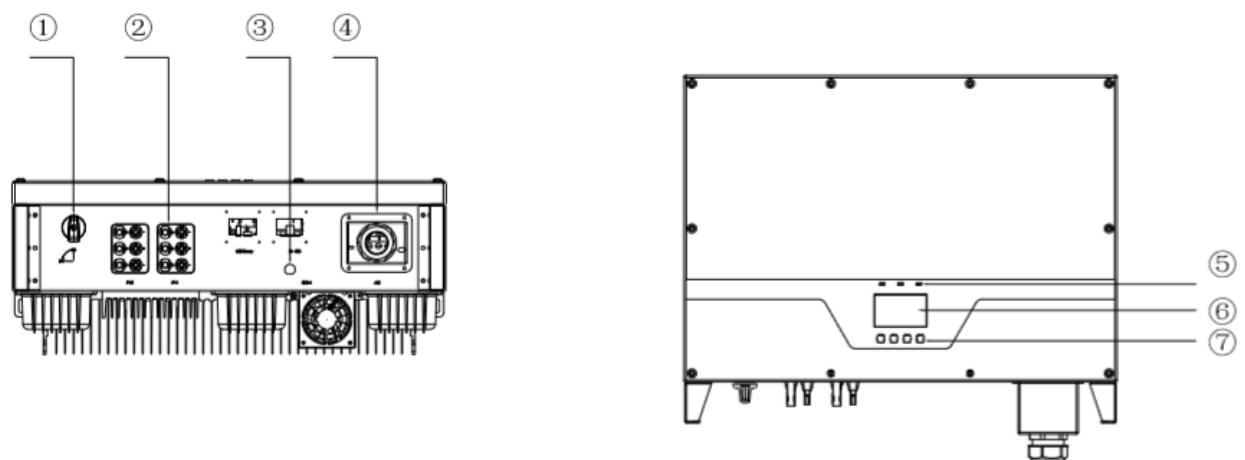



Figure 2-2 Electrical Terminals

1	DC Switch	2	DC (PV terminal)
---	-----------	---	------------------

3	Communication port	4	AC terminal
5	LED	6	Display screen
7	KEY		

 For safety reasons, the use of a DC switch is recommended. Between the PV modules and the power modules may be mandatory in some countries.

## 2.2. Electrical system design

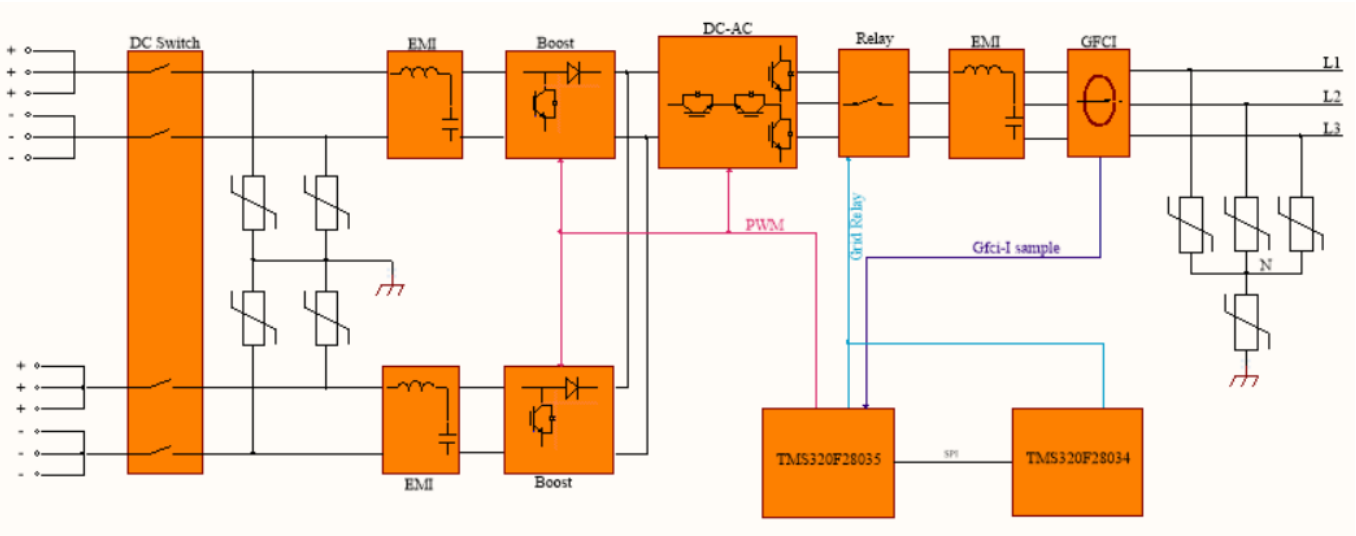

Figure 2-3 wiring diagram of the inverter system

Please refer to chapter 3 for the detail connecting and install methods.

## 2.3. Technical data

Technical Data				
Model	NAC20K-DT	NAC25K-DT	NAC30K-DT	NAC33K-DT
<b>Input (DC)</b>				
Max. DC power	26000W	32500W	37000W	39000 W
Max. input voltage	1000 Vdc			
MPP operating voltage range	250 ~ 950 Vdc			
Start-up voltage	200 Vdc			
Grid-connected voltage	350 Vdc			
Number of independent MPP inputs	2			
Max. input current per MPPT	20A+20A	20A+30A	30A+30A	30A+30A
Isc	26A+26A	26A+39A	39A+39A	39A+39A
Max inverter backfeed current to the array	0A	0A	0A	0A
strings per MPP input	2+2	2+3	3+3	3+3
DC Switch	standard			
Over voltage category	II			
<b>Output (AC)</b>				

Rated AC power	20000VA	25000VA	30000VA	33000VA
Max. AC power	22000VA	27600VA	30000VA	33000VA
Nominal AC voltage	400V			
Grid type	3+N+PE, 3+PE			
Grid voltage range	400±20%,320~480V			
Grid frequency range	50Hz/60Hz ±5Hz			
Power factor	-0.8~0.8			
Over voltage category	Ⅲ			
Rated AC current	29A	36.5A	43A	48A
Max. AC current	32A	40A	43A	48A
Max output overcurrent protection	37A	45A	48A	53A
Max output fault current	60A	60A	60A	60A
THDi	< 3%			
<b>System</b>				
Max. efficiency	98.30%	98.40%	98.50%	98.50%
European weighted efficiency	98.00%	98.10%	98.20%	98.20%
Self-consumption (night)	<1W			
Topology	Transformerless			
Cooling concept	Natural	Natural	Natural	Fan
<b>Protection</b>				
Insulation resistance monitoring	Integrated			
DC reverse-polarity protection	Integrated			
Output over current protection	Integrated			
Islanding protection	Integrated			
Residual current detection	Integrated			
Temperature protection	Integrated			
SPD protection	Standard (Type II)			
<b>General Data</b>				
Dimensions	W×H×D=660×460×255(mm)			
Weight	38Kg			
Display	240*160 dots LCD			
Communication connections	RS485, WiFi(optional), GPRS(optional)			
Operating ambient temperature range	-25 °C ~ +60 °C			
Environment category	Outdoor & Indoor			
Max.operation altitude	< 2000m			
Protection degree	IP65			
Noise	<35db @ 1 m			
Warranty	5 years/10 years			
Certificates	IEC/EN62109-1/2, IEC/EN6000-6-1/2/3/4, NB/T32004-2013, VDE0126, VDE4105, AS/NES4777.2, IEC61727, IEC62116, NB/T32004-2013			



### 3. Installation and startup



#### Warning!

Before installation and maintenance, AC and DC side doesn't carry electricity, but if DC side is just disconnected, capacitance still contains electricity, so please wait for at least 5 minutes to ensure the capacitors completely release the energy and inverter is not electrified.



#### Note!

Inverters must be installed by qualified person.

### 3.1. Package information

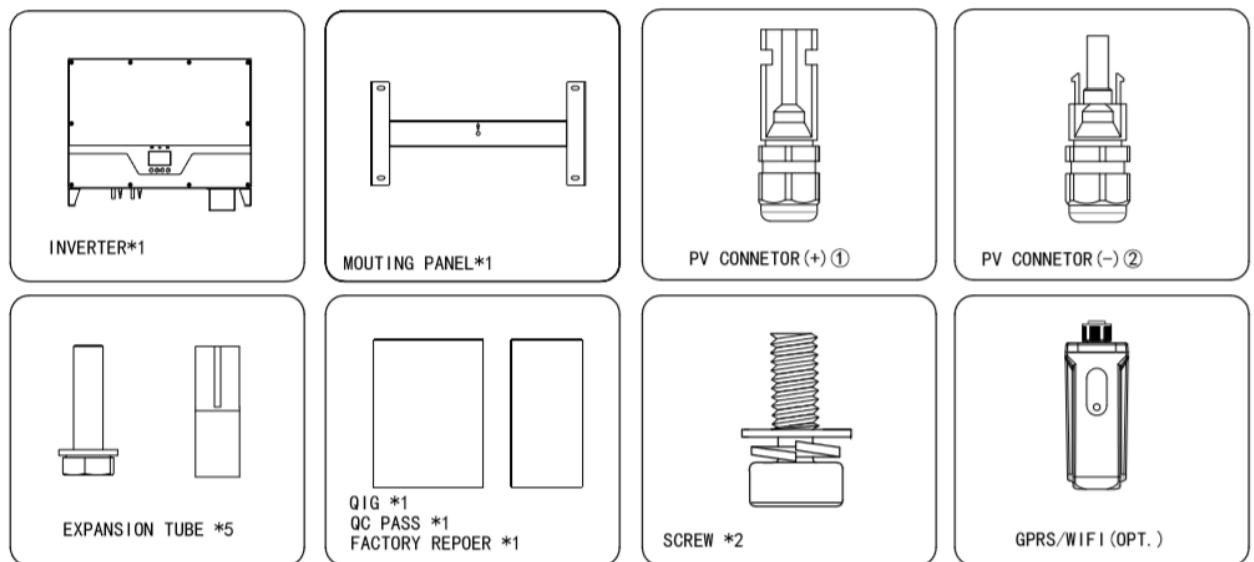

① There are 4 PV connectors for NAC20K-DT , 5 PV connectors for NAC25K-DT and 6 PV connectors for NAC30/33K-DT

② There are 4 PV connectors for NAC20K-DT , 5 PV connectors for NAC25K-DT and 6 PV connectors for NAC30/33K-DT

Figure 3-1 package information

### 3.2. Installation environment

- In order to achieve optimal performance, the ambient temperature should be kept lower than 45 °C.
- For the convenience of checking the LCD display and possible maintenance activities, please install the inverter at eye level.
- Inverters should NOT be installed near inflammable or explosive items. Any strong electro-magnetic equipment should be kept away from installation site.
- Product label and warning symbol shall be clear to read after installation.

- Please do not install inverter under direct sunlight, rain and snow.

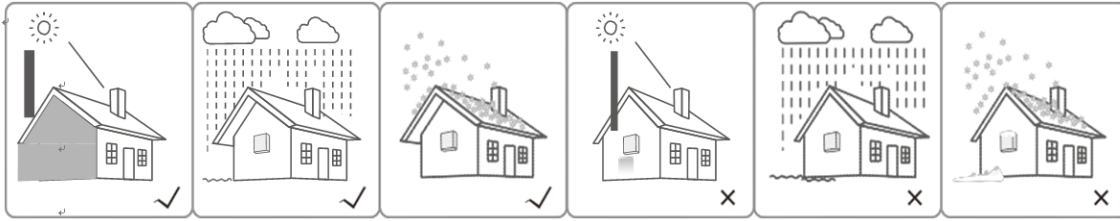

Figure 3-2 installation environment

### 3.3. Installation Position

**!**

- The installation method and mounting location must be suitable for the inverter's weight and dimensions.
- Mount on a solid surface.
- Select a well ventilated place sheltered from direct sun radiation.

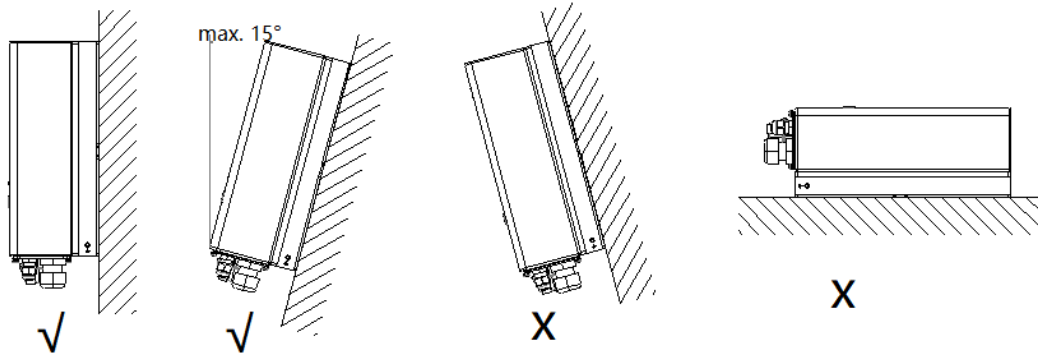

Figure 3-3 installation position

In consideration of heat dissipation and convenient dismantlement, the minimum clearances around the inverter should be no less than the following value

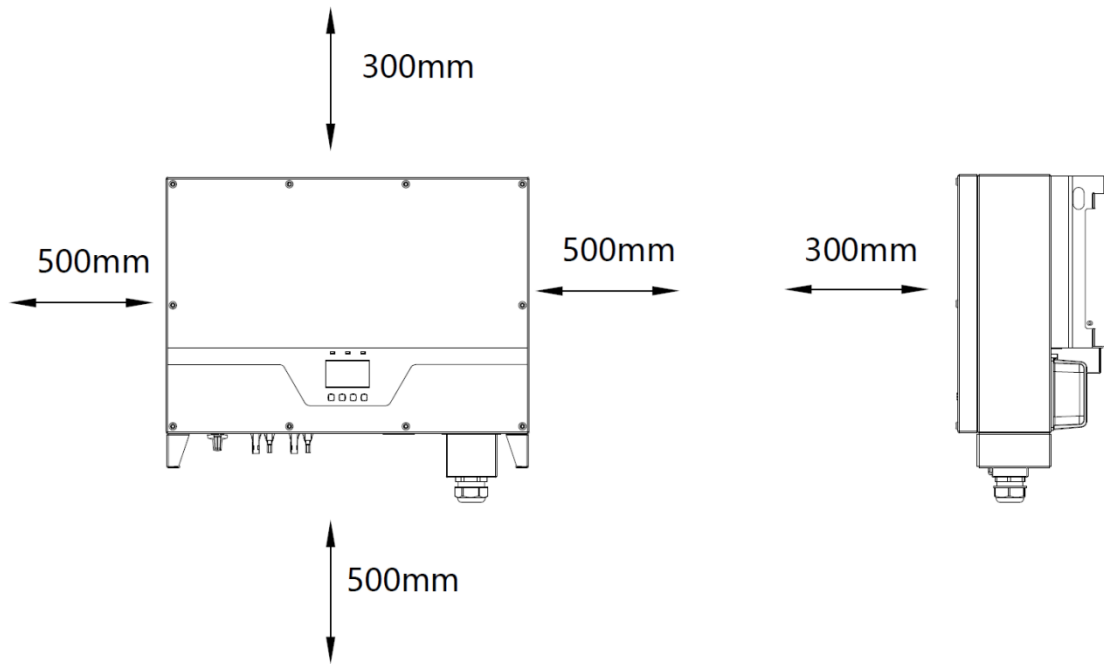

Figure 3-4 Distance required of Invertors

### 3.4. Mounting Procedure

**Step1:** Drill 4 Fix  $\varnothing 8$  holes in the wall according to the dimensions

**Step2:** Fix the wall mounting bracket on the wall with 4 expansion bolts in accessory bag

**Step4:** Place the inverter on the wall-mounted bracket and install the fix screw

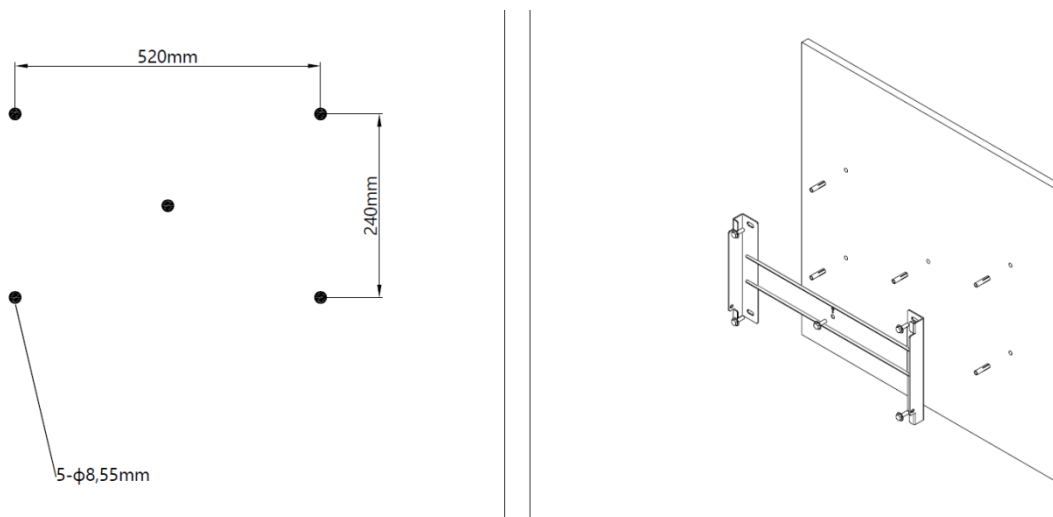

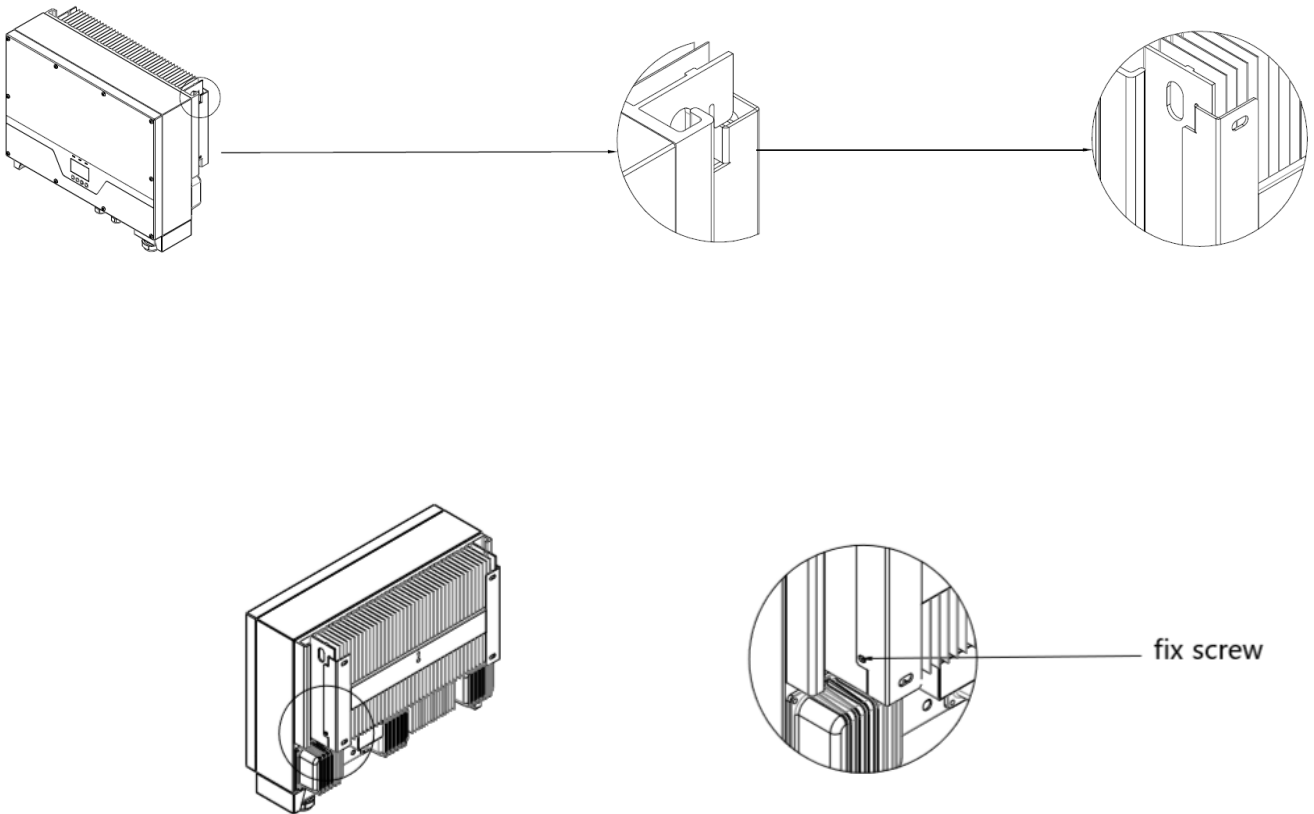

Figure 3-5 mounting the inverter

### 3.5. Electrical connection

#### 3.5.1. Connection to the grid (AC output)



- (1) Add breaker or fuse to AC side, the specification should be more than 1.25 times of rated AC output current.
- (2) The PE line of inverter should be connected to the earth, make sure the impedance of neutral wire and earth wire less than 10 ohm.
- (3) Disconnect the breaker or fuse between the inverter and the utility.
- (4) The integrated leakage current detection device of the inverter can detect external leakage current in real time. When the detected leakage current exceeds the limit value, inverter will quickly disconnect with the grid. If the leakage current protection device is installed externally, the action current should be 300mA or higher.

Connect the inverter to the grid as follows:

- (1) Strip off N/L1/L2/L3 cables as figure 3-5:

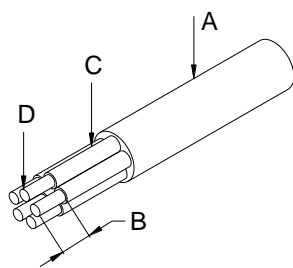

No.	Description	Remark
A	protective layer	diameter ranges : 22-27mm
B	length of stripped off	15mm
C	insulate layer	-
D	cross section of ac cables	10-16mm <sup>2</sup>

Figure 3-5 Strip off N/L1/L2/L3 cables

(2) Strip off PE cable as figure 3-6

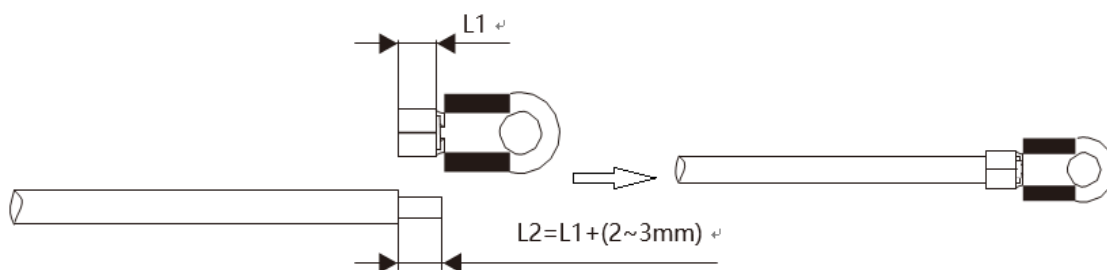

Figure 3-6 Strip off PE cables

(3) Insert AC cables through cable gland from outside, Pull the cables through and fix N/L1/L2/L3/PE cables ends to the terminals according to markings



Fix (Torque: 2~2.5 N.m) the connector of AC cable to the corresponding terminals

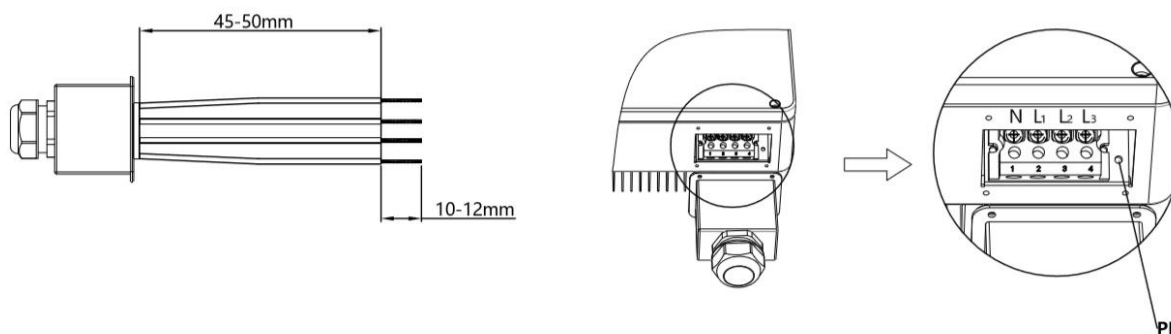

Figure 3-7 Connect the inverter to the grid

(4): Screw waterproof coupling and Screw cap nut tightly onto the cable.

### 3.5.2. Connection to PV string (DC input)



- (1) Before connecting PV string, make sure DC switch is turned off
- (2) Make sure PV string polarity confirms with DC connector, otherwise, it will cause damage to inverter
- (3) Make sure the maximum open circuit voltage ( $V_{oc}$ ) of each PV string does not exceed the inverter input voltage  $V_{max}$  under any condition
- (4) Do not connect positive or negative pole of PV string to earth wire. Otherwise, it will cause damage to inverter

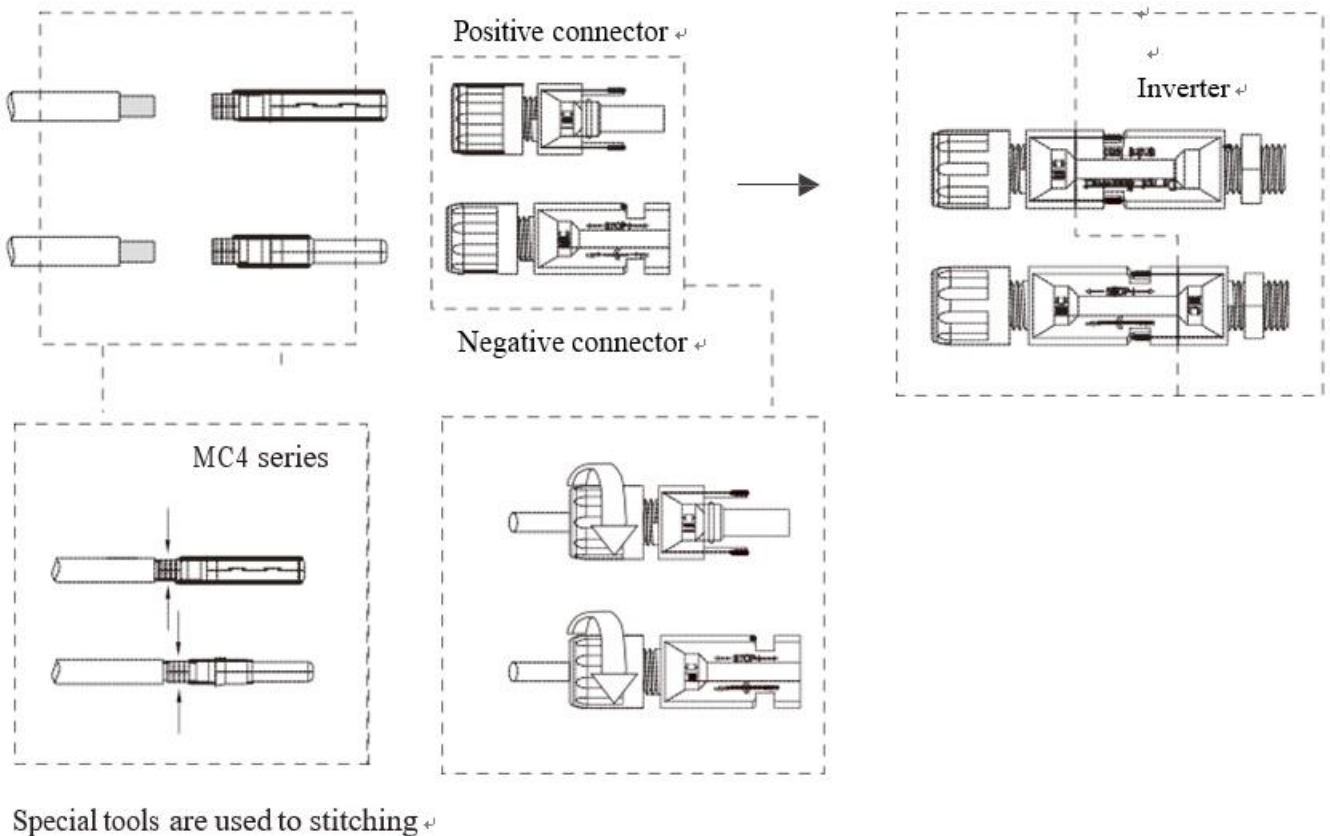

Figure 3-8 Connect the PV string

### 3.5.3. RS485/ RELAY/DI



Please make sure the RS485 connecting cables not exceed 1000m.  
Communication lines must be separated from other power lines to avoid communications interference.

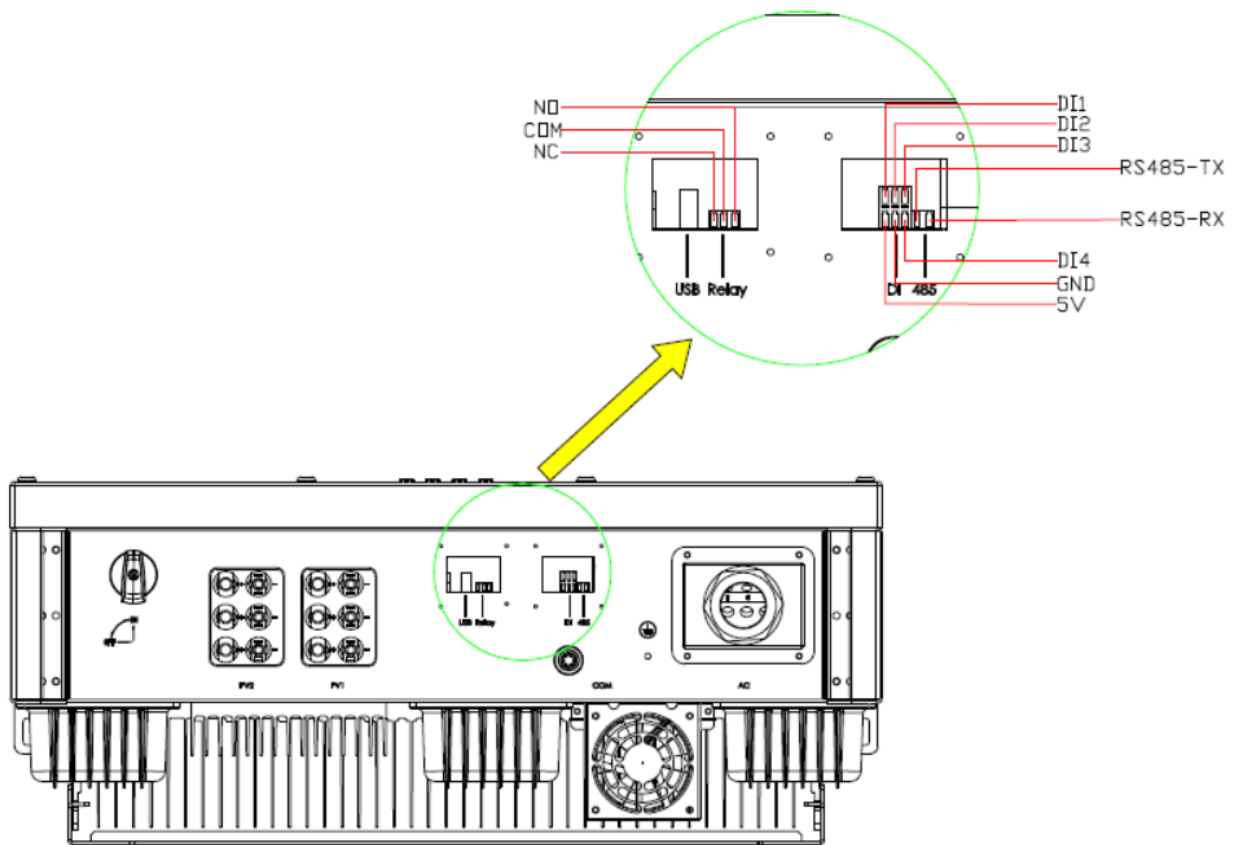

Figure 3-9 communication interface

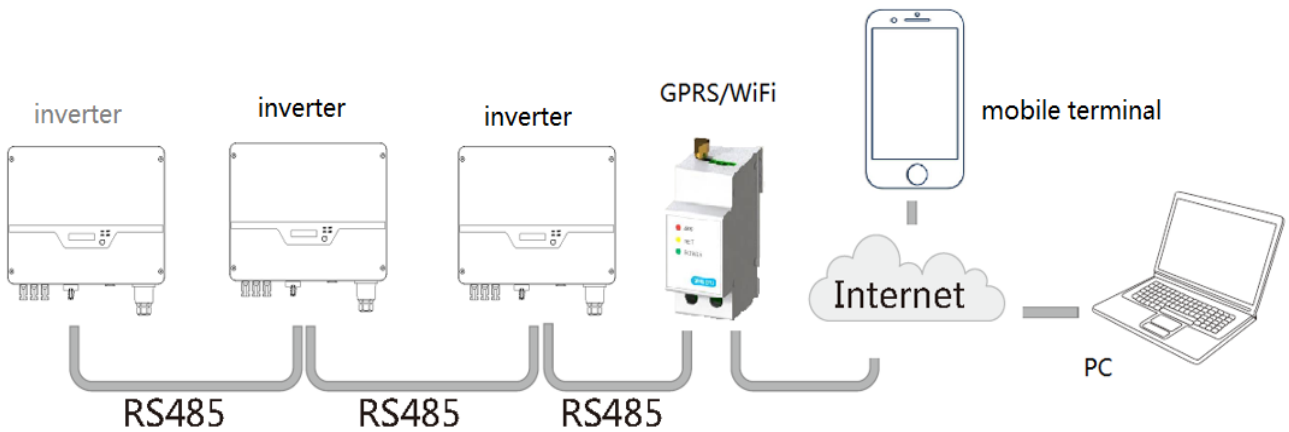

Figure 3-10 RS485 in multiple series

Interface of the RELAY and DI show in figure 3-9

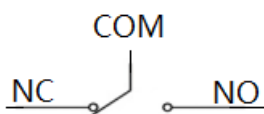

Figure 3-11 Relay interface definition

### 3.5.4. WIFI/GPRS Communication

---

By the WIFI/GPRS interface,transfer the inverter power output information, alarm information,operation state to the PC terminal or local data acquisition device

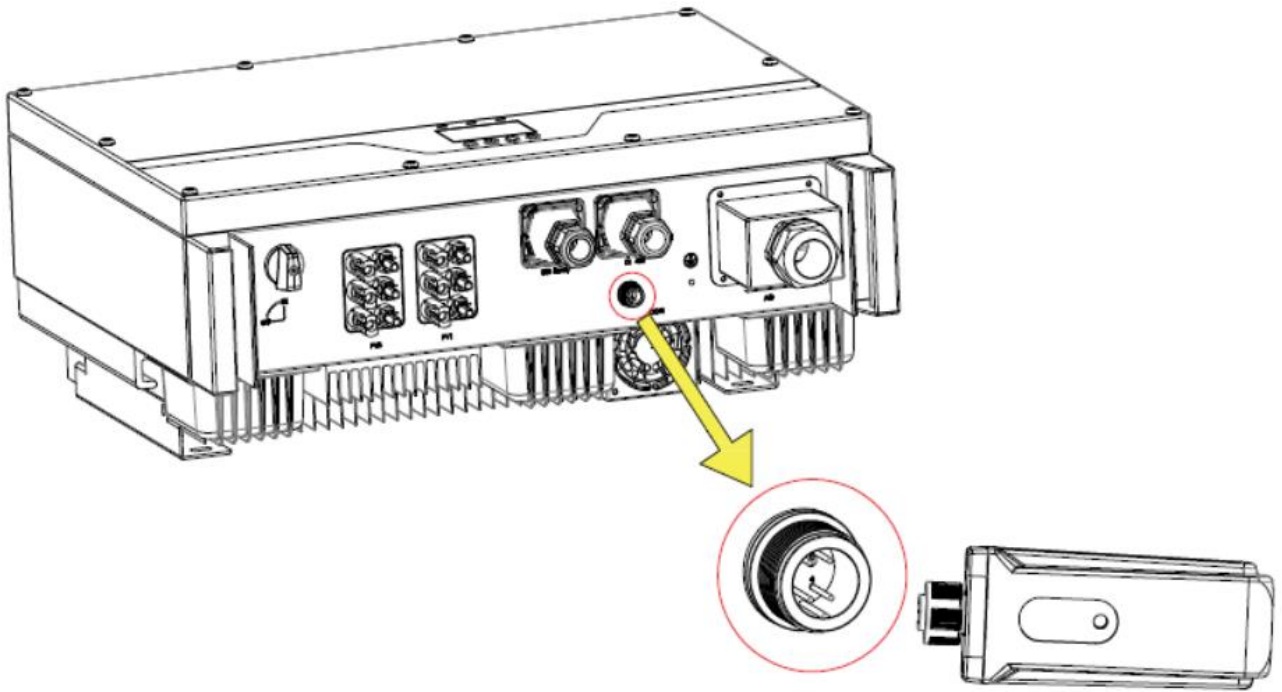

Figure 3-11 install wifi/gprs module

Please refer to the module user manual in detail.



### 3.6. Starting the Inverter

---

Before turn on the inverter, please confirm:

- a) Three phase five wires (PE/L1/L2/L3/N) cable correctly connected to the inverter AC side through AC circuit breaker;
- b) The DC cable connected correctly to the inverter DC side through DC circuit breaker, please be attention to the cable connected to the two string correctly and it's polarity;
- c) The unused terminals are covered.

Starting the inverter:

**Step1:** Close the DC and AC circuit breaker;

**Step2:** If the solar panels provide enough energy, the power module will work and the LCD panel will be lit;

**Step3:** In case you are starting the inverter for the first time, the inverter needs to be commissioned. Commissioning is described on page 17,chapter 4.3

**Step4:** Then the inverter will turn into self-check mode and the LCD panel will display the remaining time of connect simultaneously;

**Step5:** After the inverter turn into normal mode, it feed electrical energy into grid, and LCD panel will display the generated electrical energy.

As long as the inverter works, it will automatically track the maximum power point to absorb the maximum energy from solar. When night comes, the irradiance is not strong enough to provide energy, the inverter will power off automatically. When the next day comes, the input voltage reaches the start value, it will start again automatically.

## 4. User Interface

---

### 4.1. Led and Key

---

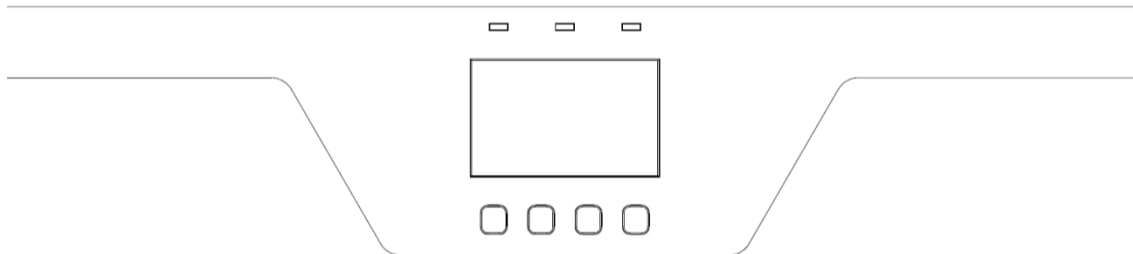

Figure 4-1 LED display

Object	Description
RUN (Green LED)	On = Normal operation
FAULT (Red LED)	On = Failure
WARNING (YELLOW LED)	On = Warning
ESC BUTTON	ESC Operation
UP BUTTON	UP Operation
DOWN BUTTON	DOWN Operation
ENTER BUTTON	ENTER Operation

### 4.2. LCD Display

---

The LCD display shows parameters of inverters which can be set through Pushbutton.

ESC BUTTON: Esc

UP BUTTON: Up

DOWN BUTTON: Down

ENTER BUTTON: Enter

None (just wait) : return

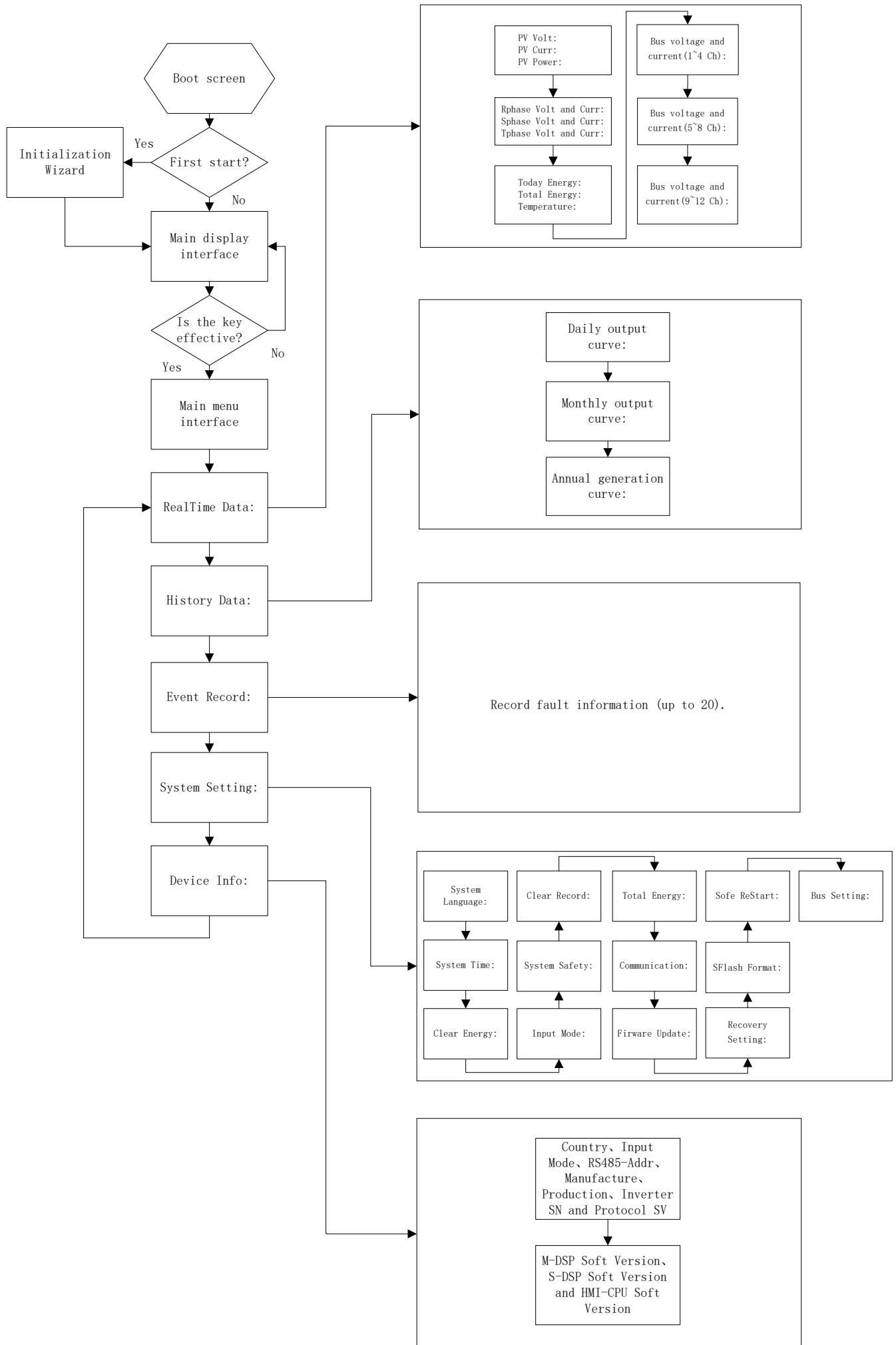

### **4.3. Language Setting**

---

- 1.Press enter button in order to enter the “menu setting” menu
- 2.Press up or down button to select the “system setting” menu
- 3.Press enter button in order to enter the “system setting” menu
- 4.Press up or down button to select the “language setting” menu
- 5.Press enter button in order to enter the “user verify” menu
- 6.Press enter button to select valid or invalid
- 7.When the selection is valid, press up or down button to adjust the user password
- 8.When the selection is invalid, press up or down button to select the “OK” item
- 9.Confirm the password by pressing the enter button(the default password is "0000"), and enter the “language setting” menu
- 10.Press enter the button to select valid or invalid
- 11.When the selection is valid, press up or down button to adjust the language
- 12.When the selection is invalid, press up or down button to select the “OK” item
- 13.Press enter button to save

### **4.4. Time Setting**

---

- 1.Press enter button in order to enter the “menu setting” menu
- 2.Press up or down button to select the “system setting” menu
- 3.Press enter button in order to enter the “system setting” menu
- 4.Press up or down button to select the “date&time setting” menu
- 5.Press enter button in order to enter the “user verify” menu
- 6.Press enter button to select valid or invalid
- 7.When the selection is valid, press up or down button to adjust the user password
- 8.When the selection is invalid, press up or down button to select the “OK” item
- 9.Confirm the password by pressing the enter button(the default password is "0000"), and enter the “date&time setting” menu
- 10.Press enter the button to select valid or invalid
- 11.When the selection is valid, press up or down button to adjust the date and time
- 12.When the selection is invalid, press up or down button to select the “OK” item
- 13.Press enter button to save

### **4.5. Clear Energy**

---

- 1.Press enter button in order to enter the “menu setting” menu
- 2.Press up or down button to select the “system setting” menu
- 3.Press enter button in order to enter the “system setting” menu
- 4.Press up or down button to select the “clear energy” menu
- 5.Press enter button in order to enter the “user verify” menu
- 6.Press enter button to select valid or invalid
- 7.When the selection is valid, press up or down button to adjust the user password
- 8.When the selection is invalid, press up or down button to select the “OK” item
- 9.Confirm the password by pressing the enter button(the default password is "0000"), and enter the

“clear energy” menu

10. Press up or down button to select the “OK” item

11. Press enter button to save

#### **4.6. Clear Record**

---

1. Press enter button in order to enter the “menu setting” menu

2. Press up or down button to select the “system setting” menu

3. Press enter button in order to enter the “system setting” menu

4. Press up or down button to select the “clear record” menu

5. Press enter button in order to enter the “user verify” menu

6. Press enter button to select valid or invalid

7. When the selection is valid, press up or down button to adjust the user password

8. When the selection is invalid, press up or down button to select the “OK” item

9. Confirm the password by pressing the enter button (the default password is "0000"), and enter the “clear record” menu

10. Press up or down button to select the “OK” item

11. Press enter button to save

#### **4.7. Safety Setting**

---

1. Press enter button in order to enter the “menu setting” menu

2. Press up or down button to select the “system setting” menu

3. Press enter button in order to enter the “system setting” menu

4. Press up or down button to select the “safety setting” menu

5. Press enter button in order to enter the “user verify” menu

6. Press enter button to select valid or invalid

7. When the selection is valid, press up or down button to adjust the user password

8. When the selection is invalid, press up or down button to select the “OK” item

9. Confirm the password by pressing the enter button (the default password is "0000"), and enter the “safety setting” menu

10. Press enter the button to select valid or invalid

11. When the selection is valid, press up or down button to select the country

12. When the selection is invalid, press up or down button to select the “OK” item

13. Press enter button to save

#### **4.8. Setting Input Mode**

---

1. Press enter button in order to enter the “menu setting” menu

2. Press up or down button to select the “system setting” menu

3. Press enter button in order to enter the “system setting” menu

4. Press up or down button to select the “input mode” menu

5. Press enter button in order to enter the “user verify” menu

6. Press enter button to select valid or invalid

7. When the selection is valid, press up or down button to adjust the user password

8. When the selection is invalid, press up or down button to select the “OK” item
9. Confirm the password by pressing the enter button(the default password is "0000"), and enter the “input mode” menu
10. Press enter the button to select valid or invalid
11. When the selection is valid, press up or down button to select the input mode
12. When the selection is invalid, press up or down button to select the “OK” item
13. Press enter button to save

#### **4.9. Setting Total Energy**

---

1. Press enter button in order to enter the “menu setting” menu
2. Press up or down button to select the “system setting” menu
3. Press enter button in order to enter the “system setting” menu
4. Press up or down button to select the “total energy” menu
5. Press enter button in order to enter the “user verify” menu
6. Press enter button to select valid or invalid
7. When the selection is valid, press up or down button to adjust the user password
8. When the selection is invalid, press up or down button to select the “OK” item
9. Confirm the password by pressing the enter button(the default password is "0000"), and enter the “total energy” menu
10. Press enter the button to select valid or invalid
11. When the selection is valid, press up or down button to adjust the total energy
12. When the selection is invalid, press up or down button to select the “OK” item
13. Press enter button to save

#### **4.10. Setting Communication**

---

1. Press enter button in order to enter the “menu setting” menu
2. Press up or down button to select the “system setting” menu
3. Press enter button in order to enter the “system setting” menu
4. Press up or down button to select the “communication setting” menu
5. Press enter button in order to enter the “user verify” menu
6. Press enter button to select valid or invalid
7. When the selection is valid, press up or down button to adjust the user password
8. When the selection is invalid, press up or down button to select the “OK” item
9. Confirm the password by pressing the enter button(the default password is "0000"), and enter the “communication setting” menu
10. Press enter the button to select valid or invalid
11. When the selection is valid, press up or down button to adjust the communication settings
12. When the selection is invalid, press up or down button to select the “OK” item
13. Press enter button to save

#### **4.11. Firmware Update**

---

1. Press enter button in order to enter the “menu setting” menu

2. Press up or down button to select the “system setting” menu
3. Press enter button in order to enter the “system setting” menu
4. Press up or down button to select the “firmware update” menu
5. Press enter button in order to enter the “user verify” menu
6. Press enter button to select valid or invalid
7. When the selection is valid, press up or down button to adjust the user password
8. When the selection is invalid, press up or down button to select the “OK” item
9. Confirm the password by pressing the enter button(the default password is "0000"), and enter the “firmware update” menu
10. Press up or down button to select the “OK” item
11. Press enter button to start upgrading.

#### **4.12. Soft ReStart**

---

1. Press enter button in order to enter the “menu setting” menu
2. Press up or down button to select the “system setting” menu
3. Press enter button in order to enter the “system setting” menu
4. Press up or down button to select the “soft restart” menu
5. Press enter button in order to enter the “user verify” menu
6. Press enter button to select valid or invalid
7. When the selection is valid, press up or down button to adjust the user password
8. When the selection is invalid, press up or down button to select the “OK” item
9. Confirm the password by pressing the enter button(the default password is "0000"), and enter the “soft restart” menu
10. Press up or down button to select the “OK” item
11. Press enter button to restart soft.

#### **4.13. SFlash Format**

---

1. Press enter button in order to enter the “menu setting” menu
2. Press up or down button to select the “system setting” menu
3. Press enter button in order to enter the “system setting” menu
4. Press up or down button to select the “sflash format” menu
5. Press enter button in order to enter the “user verify” menu
6. Press enter button to select valid or invalid
7. When the selection is valid, press up or down button to adjust the user password
8. When the selection is invalid, press up or down button to select the “OK” item
9. Confirm the password by pressing the enter button(the default password is "0000"), and enter the “sflash format” menu
10. Press up or down button to select the “OK” item
11. Press enter button to format flash.

#### **4.14. Recovery Setting**

---

1. Press enter button in order to enter the “menu setting” menu

- 2.Press up or down button to select the “system setting” menu
- 3.Press enter button in order to enter the “system setting” menu
- 4.Press up or down button to select the “recovery setting” menu
- 5.Press enter button in order to enter the “user verify” menu
- 6.Press enter button to select valid or invalid
- 7.When the selection is valid, press up or down button to adjust the user password
- 8.When the selection is invalid, press up or down button to select the “OK” item
- 9.Confirm the password by pressing the enter button(the default password is "0000"), and enter the “recovery setting” menu
10. Press up or down button to select the “OK” item
- 11.Press enter button to recovery setting.

#### **4.15. Bus Setting**

---

- 1.Press enter button in order to enter the “menu setting” menu
- 2.Press up or down button to select the “system setting” menu
- 3.Press enter button in order to enter the “system setting” menu
- 4.Press up or down button to select the “bus setting” menu
- 5.Press enter button in order to enter the “user verify” menu
- 6.Press enter button to select valid or invalid
- 7.When the selection is valid, press up or down button to adjust the user password
- 8.When the selection is invalid, press up or down button to select the “OK” item
- 9.Confirm the password by pressing the enter button(the default password is "0000"), and enter the “bus setting” menu
- 10.Press enter the button to select valid or invalid
- 11.When the selection is valid, press up or down button to select enabling or prohibiting
- 12.When the selection is invalid, press up or down button to select the “OK” item
- 13.Press enter button to save

### **5. Warranty**

---

The standard warranty period for the inverter is 60 months from the date of installation and no more than 66 months (5.5 years) from the date of shipment from factory.

#### **5.1. Warranty Claim Procedure**

---

Please report defective device with a brief error description and SN code to our service mail or service hotline for registration.

Alternatively, please contact your specific dealer or installer if your unit is defective or faulty.

To claim the warranty under the warranty terms of factory, you need to supply us with the following information and documentation regarding the faulty unit:

In the case of an exchange, the remainder of the warranty entitlement will be transferred to the replacement device. In this event, you will not receive a new certificate, as this replacement will be noted by factory..



## **5.2. Service after Warranty Expiration**

---

For products which are out of warranty, factory charges an on-site service fee, parts, labor cost and logistic fee to end-user which can be any/all of:

- On-site attendance fee: Cost of travel and time for the technician in attending on-site;
- Parts: Cost of replacement parts (including any shipping/admin fee that may apply);
- Labor: Labor time fee charged for the technician, who is repairing, maintaining, and installing (hardware or software) and debugging the faulty product;
- Logistic fee: Cost of delivery, tariff and other derived expense when defective products are sent from user to factory or/and repaired products are sent from factory to user;

## 6. Contact Information

---

If you have any further technical questions about our products, please contact us:

**Renacpower Co., Ltd**

Address: Building 6, No. 2, West Jinzhi Road, High-Tech District, Suzhou City, Jiangsu Province

Email: [service@renacpower.com](mailto:service@renacpower.com)

For further information of Trannergy warranty regulation and reliability, please visit

[www.renacpower.com](http://www.renacpower.com)

## **Appendix A: FAQ (Frequently asked questions)**

Sometimes, the PV system does not work normally; we recommend the following solutions for average troubleshooting. This can help the technician to understand the problem and take a proper action.

	LCD display	Possible actions
Clearable Fault	Isolation Fault	<ol style="list-style-type: none"> <li>1. Check whether the inverter is earthed and test impedance between PV (+) &amp; (-) and the impedance must exceed 3MΩ;</li> <li>2. Check whether the AC-side has contacts with earth.</li> </ol>
	Ground Current Fault	<ol style="list-style-type: none"> <li>1. The ground current is too high.</li> <li>2. After cutting off the AC side connection, unplug the inputs from the PV generator and check the peripheral AC system.</li> <li>3. After the cause is cleared, re-plug the PV panel and AC connection, and check PV inverter status.</li> </ol>
	Grid Fault Fac Over Range Vac Over Range	<ol style="list-style-type: none"> <li>1. Wait for 5 minutes, if the grid returns to normal, PV inverter automatically restarts.</li> <li>2. Make sure grid voltage and frequency meet the local specifications.</li> </ol>
	Utility Loss	<ol style="list-style-type: none"> <li>1. Grid is not connected.</li> <li>2. Check grid connection cables.</li> <li>3. Check grid usability.</li> <li>4. If grid is ok and the problem exists still, maybe the fuse in the inverter is open, please call service.</li> </ol>
	Over Temperature	<ol style="list-style-type: none"> <li>1. The internal temperature of inverter is higher than specified normal value.</li> <li>2. Find a way to reduce the ambient temperature.</li> <li>3. Or move the inverter to a cooler environment.</li> </ol>
	PV over Voltage	<ol style="list-style-type: none"> <li>1. Check the open PV DC voltage, and see if it is greater than or too close to 950VDC</li> <li>2. If PV DC voltage is less than 950VDC, and the problem still occurs, please call local service.</li> </ol>
Permanent Fault	Consistent Fault	Disconnect PV (+) or PV(-) from the input, restart the inverter.
	Relay-Check Fail	<ol style="list-style-type: none"> <li>1. Disconnect all PV (+) or PV (-).</li> <li>2. Wait for a few seconds.</li> <li>3. After the LCD switches off, reconnect and check again.</li> <li>4. If the problem remains, please call local service.</li> </ol>
	DC INJ High	
	EEPROM R/W Fail	
	SCI Failure	
	AC HCT Fault	
	GFCI Failure	

# RENAC

Renac Power Technology Co.,Ltd.

---

[www.renacpower.com](http://www.renacpower.com)

## Headquarters

Add: Block 6, No.2, West Jinzhi Road, Suzhou National Hi-Tech District, Suzhou, China  
Tel: 0512-66677278

---

## Wuxi Office

Add: Floor 16, Building A3, No. 77 of Jiangzhu West Rd, Wuxi, Jiangsu, China  
Tel: 0510-85161623

---